

# BAL du 13 septembre 2014

## ST ANDREW'S FAIR J32 · 3/4L

Roy Goldring: *Five Scottish Country Dances 1982* · Crib: *MiniCrib*s · Diagram: *Keith Rose's Diagrams*

- 1-8** 1s cross RH, cast 2 places, cross LH below 3s & cast up to 2nd place own sides
- 9-16** 2s+1s+3s 1/2 turn RH retain hands & all set (M face down & L up) 2L leads Ladies across & down own side **while** 3M leads Men across & up
- 17-24** 3s+1s+2s circle 6H round & back
- 25-32** 3s+1s+2s 1/2 turn LH retain hands & all set (M face up & L down) 2L leads Ladies across & up own side **while** 3M leads Men across & down

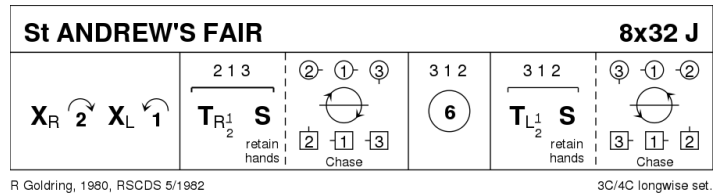

## MACPHAIL'S MAGIC R32 · 3/4L

Ann Dix: *Reel Friends Book 2* · Crib: *MiniCrib*s · Diagram: *Keith Rose's Diagrams*

- 1-4** 1s+2s set & 1M+2L 3/4 turn RH to 2M/1L places **while** 1L+2M cast 1 place down/up
- 5-8** 1L+2M 3/4 turn RH **while** 1M+2L cast down/up to original places & set advancing
- 9-16** 1s+2s dance Poussette
- 17-24** 1s+3s dance double Fig of 8 (1s cross down to start)
- 25-32** 2s+1s+3s dance reels of 3 on sides (1s in & up to start)

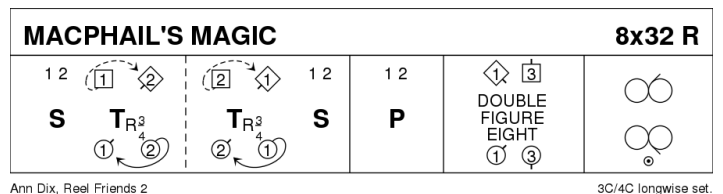

## PROGRAMME ITEM – Le 20 Novembre (One Set Short Of A Hundred) (S3x32)

1 - 81s & 2s All-round poussette 9 - 161s lead down for 3, lead up for 3 and cast to 2nd place (2s move up) 17 - 241s & 3s Tourbillon 25 - 32 All circle Repeat 3 times.

## IT'S JUST FOR FUN J32 · 3/4L

Roy Fidler: RSCDS XXXIII 6 · Crib: MiniCribbs · Diagram: Keith Rose's Diagrams

- 1-8** 1s cross RH & cast 1 place, 1M dances 1/2 Fig of 8 round 2s **while** 1L dances round 3s 1s end facing 1st corners
- 9-16** 1s dance 1/2 reel of 4 with 1st crnrs, pass LSh & dance RH across (1M with couple in 1st pl & 1L with cple in 3rd pl) 1s end facing 2nd crnrs
- 17-24** 1s dance 1/2 Reel of 4 with 2nd corners, pass partner LSh to dance RH across (1M with 2L+3L on Men's side & 1L with 2M+3M)
- 25-32** 1s 1/2 turn LH **while** 2s+3s change places RH on sides, 1M dances up & 1L down, cast on own sides **while** corners set & cross RH & all set

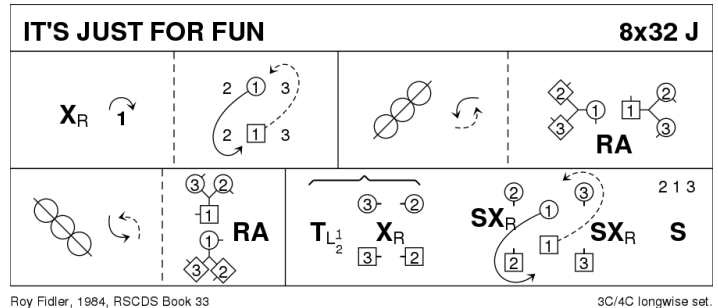

## CUILLINS OF SKYE S32 · 3/4L

Roy Goldring: Four Scottish Country Dances 1978 · Crib: MiniCribbs · Diagram: Keith Rose's Diagrams

- 1-8** 1s cross RH **while** 2s+3s change places on sides (Ladies LH & Men RH) & dance reels of 3 on the sides (1s out & down, 3s in & up)
- 9-16** 1s cast 1 place on opposite sides (3s dance up) & dance 1/2 Figs of 8 (Lady up & Man down), 1s meet in centre & turn LH 1.1/4 times
- 17-24** 1L dances RH across with top couple & 1M with couple in 3rd place, 1s pass RSh & dance LH across with other couple
- 25-32** 3s+1s+2s dance the Knot

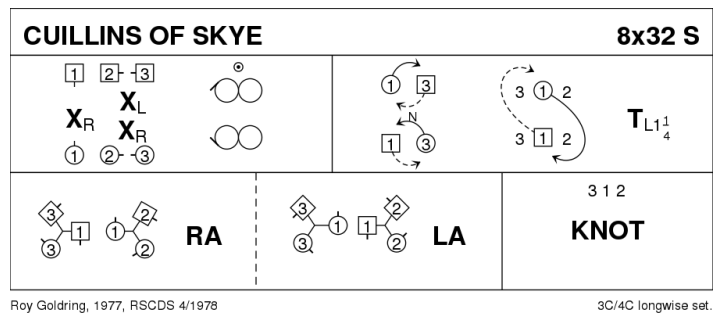

## GENERAL STUART'S REEL R32 · 3/4L

Castle Menzies (18C): RSCDS X 3 · Crib: MiniCribbs · Diagram: Keith Rose's Diagrams

- 1-8** 1M sets to 2L & casts 1 place, 1L sets to 2M & casts 1 place
- 9-16** 1s turn 1st corner RH & pass partner RSh, turn 2nd corner LH pass partner RSh to face 1st corners
- 17-24** 1s dance 'Hello-Goodbye' setting & end BtoB (1M facing up & 1L facing down)
- 25-32** 1s give RSh to 2nd corner & dance reels of 3 on sides with 2s+3s & cross RH to 2nd place on own sides

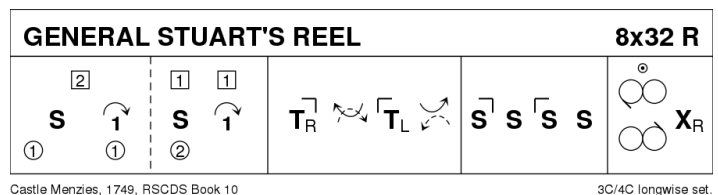

## PROGRAMME ITEM – Interval

# THE DRUNKEN SAILOR

R32 · 3/4L

Edwin Werner · Crib: MiniCribs

- 1-8 1s set & cross RH, cast 1 place & set advancing & turn about to face opposite sides
- 9-16 1s dance Double Triangles & end facing opposite sides
- 17-24 1s dance Figs of 8 round 2s/3s (RSh to 1st corner to start) & end facing 3rd corners
- 25-32 1s dance 'Hello-Goodbye' setting & end turning LH to 2nd place

# THE SPIRIT OF THE DANCE

S32 · 3/4L

Irene Paterson: T.A.C. 50th Anniversary Collection · Crib: MiniCribs · Diagram: Keith Rose's Diagrams

- 1-8 1s+2s dance a Tourbillon:  
 1- 4 1s & 2s 1/2 turn ptrns 2H, 1M & 2L lead ptrns by nearer hand 1 place cl'wise to end 1s on Ladies side & 2s Men's side, 1s set to 2s  
 5- 8 1s & 2s 1/2 turn ptrns 2H & lead ptrns on 1 place clockwise & 2s+1s cross RH to own sides
- 9-16 1s cast to right on own sides & pass RSh in middle of set, cast to right again & pass RSh to end in 2nd place on opposite side.
- 17-28 2s+1s+3s dance 3 couple R&L
- 29-32 1s turn 1.1/2 times to 2nd place own sides. 2 1 3

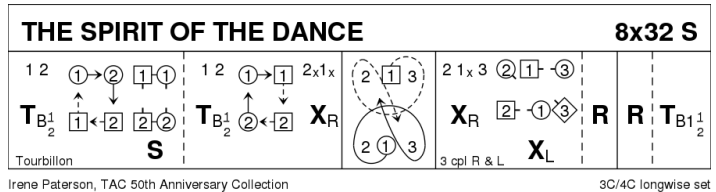

# BACK TO BACK

J32 · 3/4L

Terry Glasspool: An Itch to Dance · Crib: MiniCribs · Diagram: Keith Rose's Diagrams

- 1-8 1s dance DoSiDo, turn RH & cast to 2nd place
- 9-16 1s dance DoSiDo, turn RH 1.1/2 times to end 2nd place opposite sides facing 1st corner
- 17-24 1s dance RSh reels of 3 on opposite sides **while** 2s+3s dance DoSiDo on sides (pass RSh) & dance DoSiDo on sides (pass LSh)
- 25-28 1s turn 1st corner RH to end BtoB facing opposite sides & all set in double triangle position
- 29-32 1L dances up between 2s & casts to 2nd place own side **while** 1M dances down between 3s & casts up to 2nd place own side

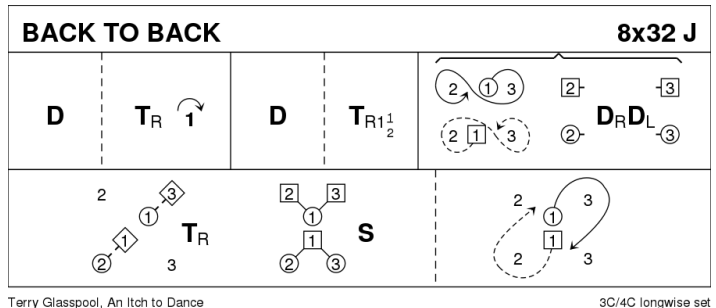

# DAVID'S DELIGHT

S32 · 3/4L

Muriel A Johnstone: Dancing on Air

# FOLLOW ME HOME

J32 · 3/4L

Ellie Briscoe: RSCDS XXXVIII 3 · Crib: MiniCribbs · Diagram: Keith Rose's Diagrams

- 1-8** 1s set & cross RH, cast 1 place & turn LH (ending in a diagonal line LH to partner & RH with 1st corner)
- 9-16** 1s Bal-in-Line with 1st cnrs, 1/2 turn cnrs & 1s followed by cnrs chase cl'wise to 3rd cnr (pstrn) & 1s dance in to give LH to 2nd cnrs
- 17-24** 1s Bal-in-Line with 2nd cnrs, 1/2 turn cnrs & 1s followed by cnrs chase anticl'wise to 4th cnr (pstrn) & 1s end in 2nd pl opp sides
- 25-32** 3s+1s+2s dance 1/2 reels of 3 on the sides 1s giving LSh to 2nd corner (pstrn), set & cross RH

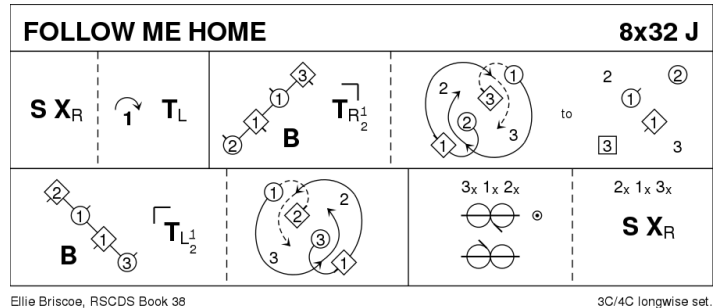

# THE REEL OF THE ROYAL SCOTS

R32 · 3/4L

Roy Goldring: The Leaflet Dances with Music · Crib: MiniCribbs · Diagram: Keith Rose's Diagrams

- 1-8** 1s 1/2 turn 2s on sides (1M RH - 1L LH) to face out, 2s+1s+3s set, 1s 1/2 turn 3s on sides (1M LH - 1L RH) end 3s facing out & 2s+3s+1s set
- 9-16** 1s followed by 3s dance up between 2s, cast down 1 place, dance in & 1s cast up to 2nd place 3s end in 3rd place
- 17-24** 1s turn 1st corners RH, pass partner RSh turn 2nd corners RH & cross passing partner RSh to 2nd place own sides
- 25-32** 2s+1s+3s circle 6H round & back

