

2016-06-18 Paris Summer dance

1 MISS HADDEN'S REEL J32 · 3/4L

RSCDS: RSCDS XXIII 5 · Crib: Eric Ferguson's SCD Cribs · Diagram: Keith Rose's Diagrams

- 1- 1c+2c+3c Circle6 and back
- 9- 1c set | cast off (2c up) ; 2c+1c+3c turn RH into
- 17- 2c+1c+3c Allemande (3,1,2)
- 25- All A&R ; 3c followed by 1c cast off and 2c dance up to (2,1,3) (second time: 3c dance through 4pl to 3pl and 1c dance to 4pl)

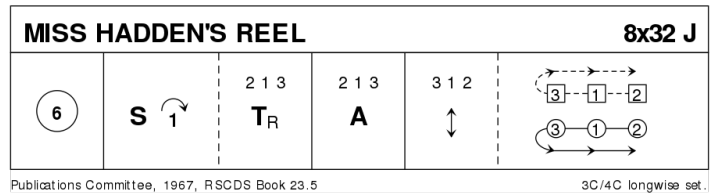

2 THE LASS O' LIVINGSTON R32 · 2/4L

John Lowe: RSCDS VIII 6 · Crib: Eric Ferguson's SCD Cribs · Diagram: Keith Rose's Diagrams

- 1- 1M+2W turn RH, to places ; 1W+2M repeat
- 9- 1c lead down the middle and up
- 17- 1c+2c Pousette
- 25- 2c+1c R&L

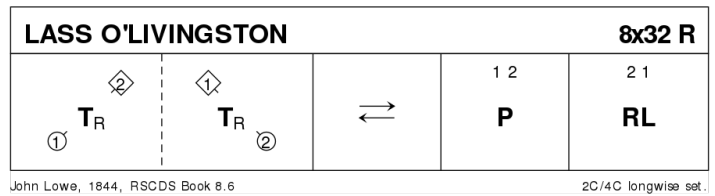

3 GANG THE SAME GATE S32 · 3/4L

Milton Levy: RSCDS XXXVI 4 · Crib: Eric Ferguson's SCD Cribs · Diagram: Keith Rose's Diagrams

- 1- 1c cross RH | cast off 2 (2c+3c up) ; 1c cross RH and cast up (3c down) to (2,1,3)
- 9- 1c set passing Lsh | turn 1cnrs BH ; ½Reel4 with 2cnrs, at end 1c curve R to between end cpl (M above facing W below)
- 17- 1c set passing Lsh, turn 4cnr (2cnr persons) BH ; ½Reel4 with 1cnrs, at end curve R to (3x,1x,2x)
- 25- All S&Link3 ; repeat (2,1,3)

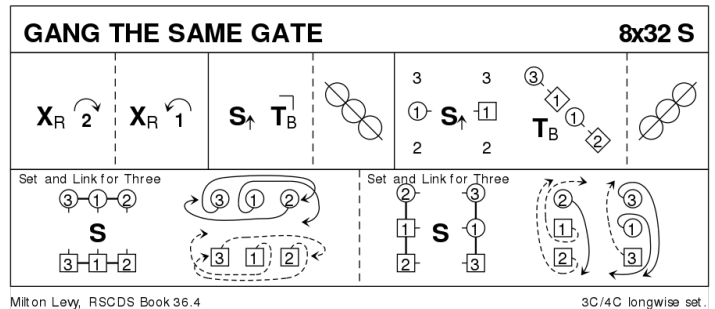

4 MAJOR IAN STEWART J32 · 3/4L

John Drewry: RSCDS XXXV 4 · Crib: Eric Ferguson's SCD Cribbs · Diagram: Keith Rose's Diagrams

- 1- 1c+2c turn RH ½ into | ½ RHA into ;
2c+1c turn RH, 2c finish facing out
(2,1,3)
- 9- Opposing Reels3 on own sides (1c
inwards, Rsh to 4cnr) 1c finish facing
1cnr, 2c+3c finish with loops
- 17- SetH&G to (2,1,3)
- 25- Circle6 L {3}, cross R foot over L and chase back cclw to (2,1,3)

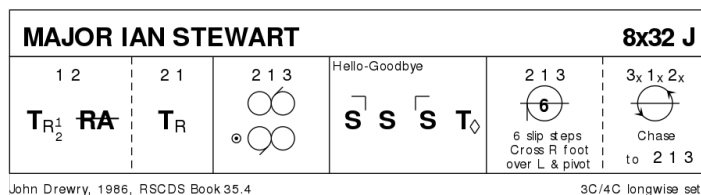

5 THE ROYAL WEDDING S32 · 3/4L

Gene A MacKinnon: Five Scottish Country Dances 1982 · Crib: Eric Ferguson's SCD Cribbs · Diagram: Keith Rose's Diagrams

- 1- 1c set | turn BH (2c dance up) ; dance
down one place | turn BH to face 1cnr
(1M helps 1W using RH)
- 9- 1c turn 1cnr RH finishing between end
couples, facing P | 1c set to P
advancing to face 2cnrs **while**{2}
2c+3c set facing diagonally ; 1c turn 2cnr RH and finish between corners | 1c set advancing to
face 3cnr **while**{2} 2c+3c set as before
- 17- 1c+3cnrs ½Reel4, pass Lsh ; 1c+4cnrs ½Reel4, 1c pass P Lsh and dance out into
- 25- 3c+1c+2c chase clw ½ round ; 2c+1c+3c turn BH

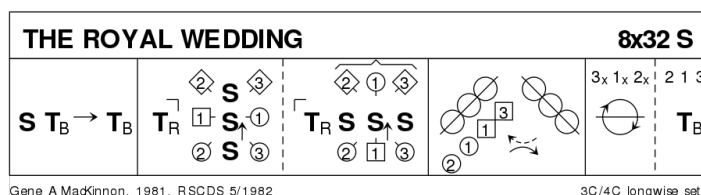

6 THE SAILOR R32 · 3/4L

RSCDS XXIV 4 · Crib: Eric Ferguson's SCD Cribbs · Diagram: Keith Rose's Diagrams

- 1- 1c cross down RH (2c up) to 2plx and
BiL with cnrs ; 1c cast R into lines
across | all set
- 9- All Reels3 across, Rsh to 1cnr, finishing
(2,1x,3)
- 17- 1c lead down | lead to the top ; cross
and cast to (2,1,3)
- 25- 2c+1c R&L.

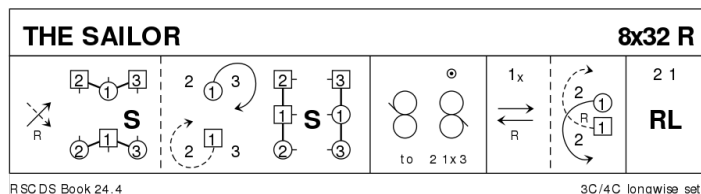

Note: [3-4] is NOT in DTr position.

7 MISS ALLIE ANDERSON J32 · 3/4L

Mina Corson: The Leaflet Dances with Music · Crib: Eric Ferguson's SCD Cribbs · Diagram: Keith Rose's Diagrams

- 1- All clap, 1W+2W+3W dance Rsh once
round P to face down with him RHJ ;
All lead down the middle
- 9- All M turn P under R arm and lead up
to (1x,2x,3x) ; All set, ½ RH turn into
- 17- 1c+2c+3c Promenade (1,2,3)
- 25- 1c+2W RHA, 1M finishing 2pl own side (2M up on [3-4]) ; 1c+2M LHA (2W up on [7-8]) to (2,1,3)

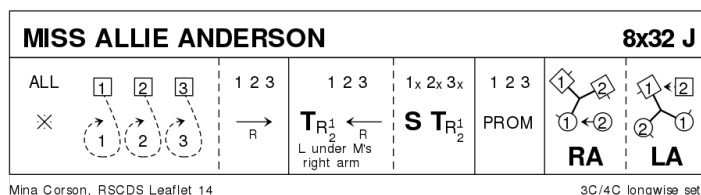

8 THE BRAES OF TULLIEMET S32 · 3/4L

Castle Menzies (18C): RSCDS VII 12 · Crib: Eric Ferguson's SCD Cribbs · Diagram: Keith Rose's Diagrams

- 1- 1c set | cast off (2c up) ; cross RH | cast off (3c up) (2,3,1x)
- 9- 3c+1c circle4 L, to sidelines ; 1c dance to the top | cast off to face 1cnrs (3c down)
- 17- 1c set to and turn corners
- 25- Reels3{6} on the sides (Lsh to 1cnr) | 1c cross over (2,1,3)

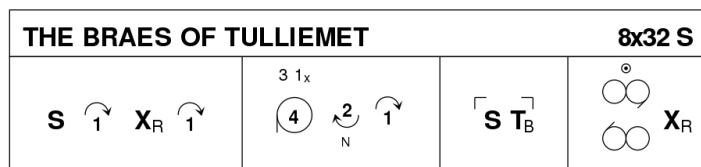

Castle Menzies, 18C, RSCDS Book 7.12

3C/4C longwise set.

9 BACK TO THE FIRESIDE R32 · 3/4L

Roy Goldring: RSCDS XXXVIII 4 · Crib: Eric Ferguson's SCD Cribbs · Diagram: Keith Rose's Diagrams

- 1- 3c followed by 1c dance down the middle | set ; dance up the middle, 1c cast off to 3pl **while**{2} 3c dance up to 1pl (3,2,1)
- 9- »pick-up chain«, from below: 1c cross RH, 1c+2c change places LH ; 1c+3c change places RH **while**{2} 2c cross RH ; 1c cross LH **while**{2} 3c+2c change places LH (to 1, 2x, 3)
- 17- 1c+2c set advancing to join NH in a circle | releasing hands, 1c+2c Petronella one place R ; Set NHJ | repeat petronella, to sidelines (2,1x,3)
- 25- 1c ½ Fig8 L (W up, M down) ; All turn RH (2,1,3)

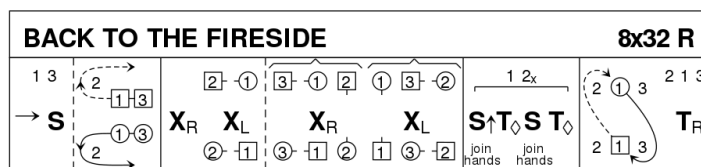

Goldring, RSCDS Book 38.4

3C/4C longwise set.

10 LADIES' FANCY J32 · 2/4L

RSCDS XIII 12 · Crib: Eric Ferguson's SCD Cribbs · Diagram: Keith Rose's Diagrams

- 1- 1M+2W turn RH, to places ; 1M+1W 1½ LH turn (1c may use BH on [7-8] as 2W steps up) to face down in line across 1W+1M+2W
- 9- 2W+1M+1W down the middle and up (1M hands 1W across in front as 2M joins in behind him for)
- 17- 1c+2c RHA, LHA
- 25- 1c+2c Poussette.

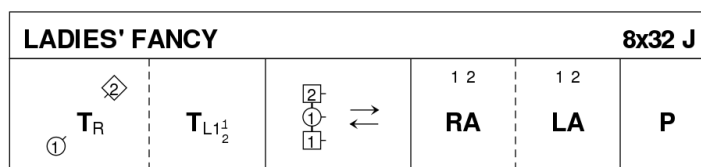

RSCDS Book 13.12

2C/3C longwise set.

11 NEIDPATH CASTLE S32 · 3/3L

Derek Haynes: RSCDS XXII 9 · Crib: Eric Ferguson's SCD Cribbs · Diagram: Keith Rose's Diagrams

- 1- All set | all turn BH twice | all set
- 9- G-Chain (1c cross to start)
- 17- 1c Fig8 on own side round 2c+3c, starting inwards. On [24] 1c+2c dance in for
- 25- 1c+2c ½ Poussette, on [28] 1c continue slow turn and 3c dance in ; 1c+3c ½ Poussette (2,3,1)

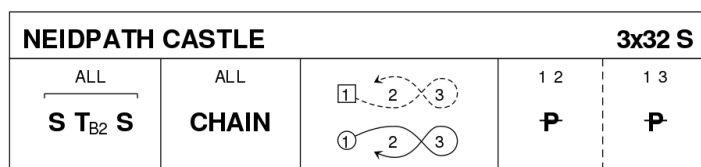

Derek Haynes, RSCDS Book 22.9

3C/3C longwise set.

12 THE REEL OF THE ROYAL SCOTS

R32 · 3/4L

Roy Goldring: *The Leaflet Dances with Music* · Crib: *Eric Ferguson's SCD Crib*s · Diagram: *Keith Rose's Diagrams*

- 1- 1W+2W (1M+2M) turn LH (RH) ½, finishing 1c BtoB in 2pl | All set as in DTr ; 1W+3W (1M+3M) turn RH (LH) ½ | 2c+3c+1c set as in DTr
- 9- 1c followed by 3c dance up between 2c, cast off ; dance NHJ down through 3pl, cast up to face 1cnrs, 3c looping into 3pl
- 17- 1c turn 1cnrs RH, pass Rsh (cnrs dance for {4}) ; turn 2cnrs RH (same), and cross Rsh to (2,1,3)
- 25- All circle6 and back

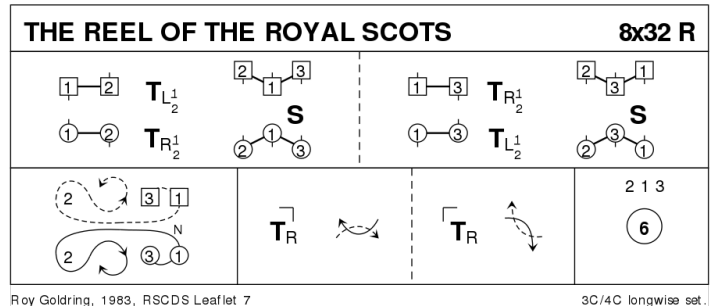

13 THE DEIL AMANG THE TAILORS

R32 · 3/4L

RSCDS XIV 7 · Crib: *Eric Ferguson's SCD Crib*s · Diagram: *Keith Rose's Diagrams*

- 1- 1c+2c set, ½ RHA ; set, ½ LHA
- 9- 1c lead down the middle and up, 2c step in for
- 17- 1c+2c Allemande
- 25- 2c+1c+3c circle6 and back.

