

Paris Branch 35th anniversary evening dance

1 CHRISTINE M PHILLIPS J32 · 3/4L

John Brenchley: RSCDS XLVI 1 · Crib: MiniCribs · Diagram: Keith Rose's Diagrams

- 1-8** 1s set advancing & lead down below
3s crossing 1s cast to 2nd place opp
sides & turn LH to face 1st corners
- 9-16** 1s dance 1/2 reel of 4 with 1st corners,
1s turn 3rd corners (pstrn) RH & turn
LH to face 2nd corners
- 17-24** 1s dance 1/2 reel of 4 with 2nd
corners, 1s turn 4th corners (pstrn) RH
& turn LH to Man facing up Lady down
- 25-32** 1M+3s (at top) also 1L+2s dance RH
across, 1s turn LH to 2nd place own sides **while** 2s+3s chase 1/2 way clockwise

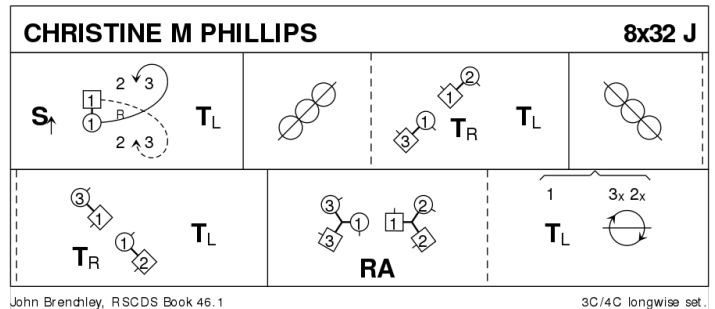

2 THE DANCING MAN R32 · 3/4L

Roy Goldring: A Second Book of Graded Scottish Country Dances · Crib: MiniCribs · Diagram: Keith Rose's Diagrams

- 1-8** 1s & 2s turn RH once round & dance
RH across once round
- 9-16** 1s+2s+3s dance RSh reels of 3 on
own sides, 1s & 2s continue reels &
loop round at top to 2M facing 1M & 2L
facing 1L (1M+2L BtoB in middle)
- 17-24** 1s+2s dance 3/4 reel of 4 across (2M & 1L pass LSh end bar 22) then pass partners RSh to
progressed places own sides (2 1 3)
- 25-32** 2s+1s+3s circle 6H round & back

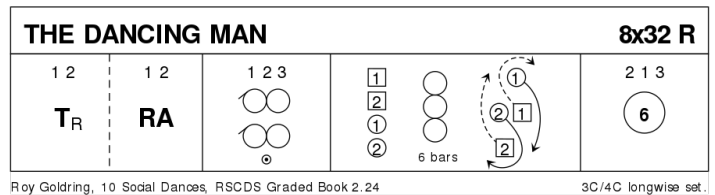

3 THE SPIRIT OF THE DANCE S32 · 3/4L

Irene Paterson: T.A.C. 50th Anniversary Collection · Crib: MiniCribs · Diagram: Keith Rose's Diagrams

- 1-8** 1s+2s dance a Tourbillon:
1- 4 1s & 2s 1/2 turn ptrns 2H, 1M & 2L
lead ptrns by nearer hand 1 place
cl'wise to end 1s on Ladies side & 2s
Men's side, 1s set to 2s
- 5- 8** 1s & 2s 1/2 turn ptrns 2H & lead
ptrns on 1 place clockwise & 2s+1s
cross RH to own sides
- 9-16** 1s cast to right on own sides & pass
RSh in middle of set, cast to right again
& pass RSh to end in 2nd place on opposite side.
- 17-28** 2s+1s+3s dance 3 couple R&L
- 29-32** 1s turn 1.1/2 times to 2nd place own sides. 2 1 3

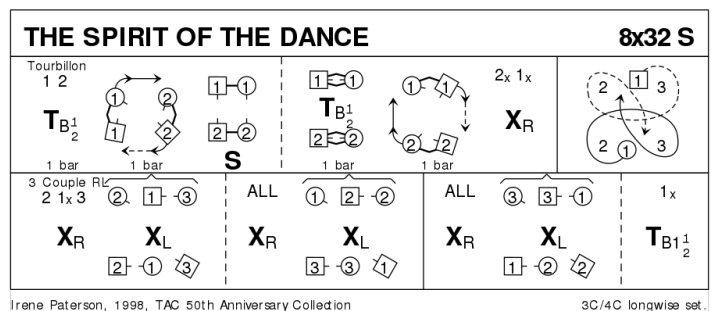

4 NEIL M GRANT J32 · 3/4L

Christine Grant: RSCDS XLIX 1 · Crib: MiniCribs · Diagram: Keith Rose's Diagrams

- 1-8** 1s cross RH, cast (2s step up). 1s dance 1/2 Figs 8 (1M round 2s, 1L round 3s) & join LH giving RH to 1st corners
- 9-16** 2s+1s+3s dance The Spoke: 1s Bal-in-Line with 1st corners, then 2nd, 3rd & 4th corners. 1s finish facing 1st corners
- 17-24** 1s dance 1/2 diagonal reel of 4 with 1st corners, pass RSh, dance 1/2 diagonal reel of 4 with 2nd corners to finish in 2nd place, opp sides facing clockwise
- 25-32** 3s+1s+2s dance clockwise 1/2 way round. 1M+3s & 1L+2s dance RH across

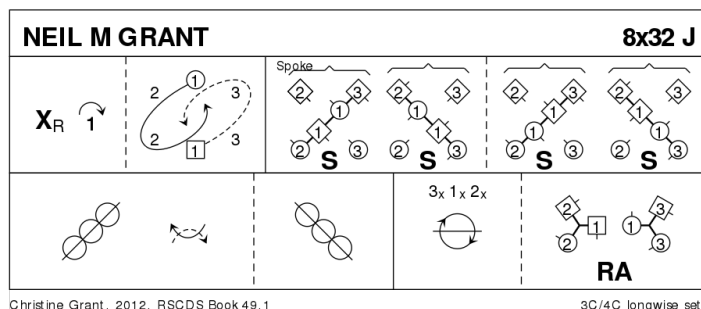

5 CRAIGLEITH R88 · 4S

Roy Goldring: A Third Book of Graded Scottish Country Dances · Crib: MiniCribs · Diagram: Keith Rose's Diagrams

- 1-8** 1s+3s dance R&L
- 9-16** 1s+3s dance Ladies' Chain
- 17-32** 2s+4s repeat bars 1-16
- 33-40** All Ladies Adv+Ret for 2 steps & dance RH across to places facing out
- 41-48** All Ladies dance clockwise round outside of set
- 49-56** All Men Adv+Ret for 2 steps & dance LH across to places facing out
- 57-64** All Men dance anticlockwise round set
- 65-72** 1s+3s Promenade anticlockwise round inside of set & set facing in
- 73-80** 2s+4s Promenade clockwise round inside of set & set facing in
- 81-88** All circle 8H round & back

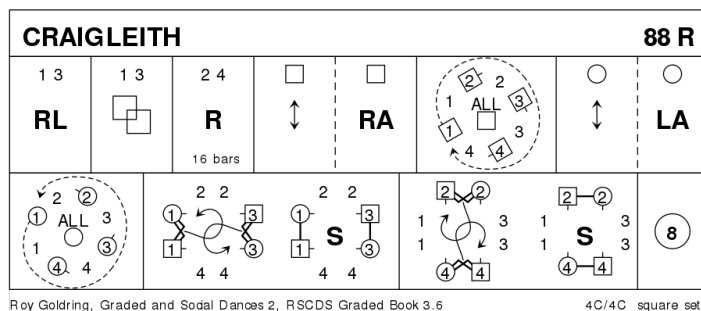

6 THE CRAMOND WEDDING S32 · 3/3L

Roy Goldring: 15 Social Dances · Crib: MiniCribs · Diagram: Keith Rose's Diagrams

- 1-8** 1s cross down to 2nd place opp sides (no hands) 1M faces out/down, 1L out/up & 2s+1s+3s dance reels of 3 (1s pass 1st corners RSh to start). 1s end facing 1st corners
- 9-12** 1s set to 1st corners & turn 2H opening out into lines of 3 across (1L between 2s & 1M between 3s) 1s+corner NHJ make an arch
- 13-16** 1s+2s+3s cross up/down 2L/3M dancing under arches made by 1s+corners, 1s turn 1st corners 2H onto sides 3 (1) 2
- 17-24** 1s dance RH across (1M+3s at top & 1L+2s at bottom), 1L crosses up between 3s & casts to 2nd place own side as 1M crosses down between 2s & casts to place
- 25-32** 3s+1s+2s dance Allemande ending with 1s casting to 3rd place as 3s dance up to 2nd place

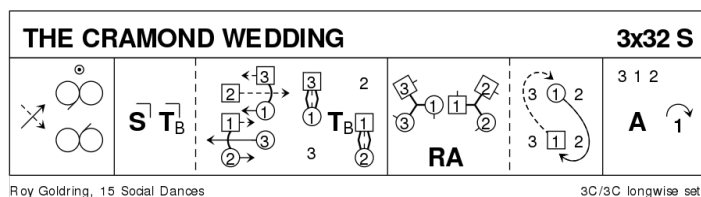

7 ELLIE'S JIG J32 · 3/4L

Melbourne Briscoe: Slip Knot Collection plus 7 More · Crib: MiniCribs · Diagram: Keith Rose's Diagrams

- 1-8 1L passes ptrn LSh & dances down behind Men, cross below 3s & dances up to pl **while** 2L (on bar 3) & 3L (on bar 5) pass ptrn LSh & follow to pl
- 9-16 Men repeat passing partners RSh
- 17-24 1s+2s dance the Slip Knot (usual Knot but end by passing Lady in front & dancing 1/2 LH across back to original places)
- 25-32 1s+2s dance Poussette. 2 1 3

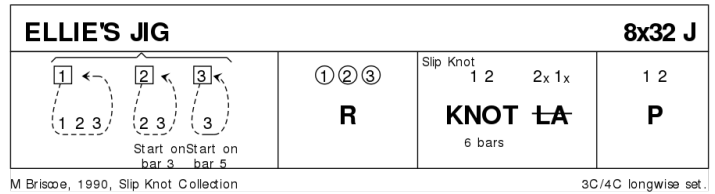

8 ALLTSHELLACH S32 · 2/4L

Elizabeth D Gilroy: RSCDS XXIII 2 · Crib: MiniCribs · Diagram: Keith Rose's Diagrams

- 1-8 1s+2s set to partners, turn 2H & dance 1/2 Diamond Poussette
- 9-16 1s followed by 2s lead down & back to original places (2s dividing & turn in behind 1s)
- 17-24 1s+2s dance reel of 4 across (1L & 2M passing LSh to start)
- 25-32 1s+2s dance Tournee:
1s+2s dance into prom hold (Men with ptrn on right, 1s face M's side & 2s L's side), couples 1/2 wheel anticl'wise & Men turn Ladies into middle, both couples turn 1.1/2 times (2s RH, 1s LH) & dance out to places

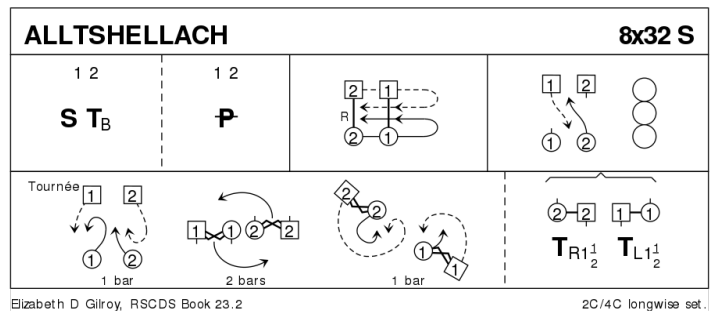

9 STARLIGHT R32 · 3/4L

Ed Abdill: RSCDS XLIV 1 · Crib: MiniCribs · Diagram: Keith Rose's Diagrams

- 1-8 1s cross RH, cast 1 place, PdB in turn right about to face opposite sides & set as double triangles
- 9-16 1s dance out, cast round 1st corners into centre **while** 2s+3s Adv+Ret diagonally, 1s PdB towards each other & turn right about to face up/down & set as double triangles
- 17-24 1s dance up/down, cast to right to 2nd place own sides **while** 2s+3s Adv+Ret, 1s dance RH across (1L with 2s & 1M +3s) end facing 1st crnrs
- 25-32 1s dance 'Hello-Goodbye' setting ending with petronella turn to 2nd places

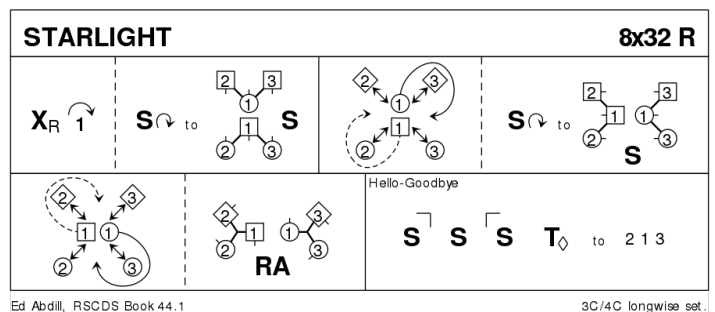

INTERVAL

10 SUENO'S STONE R32 · 3/4L

Neil M Grant: Magazine Dances 2005-2009 · Crib: MiniCribs · Diagram: Keith Rose's Diagrams

- 1-8** 1s turn RH & cast 1 place, 1s turn LH 1.1/2 times to face 2nd corners (side by side holding LH)
- 9-16** 1s set to 2nd corners & turning inwards set to 4th corner, 1s dance 1/2 reel of 4 with 4th corners & end facing 1st corners (holding LH)
- 17-24** 1s set to 1st corners & turning inwards set to 3rd corner, 1s dance 1/2 reel of 4 with 3rd corners & end in middle facing partner (1M down, 1L up)
- 25-28** 2s+3s set & dance on clockwise 1 place **while** 1s turn RH 1.1/2 times to end 1L between 2L+3L (at top) & 1M between 2M+3M
- 29-32** All chase on 1 place to own sides & set. 2 1 3

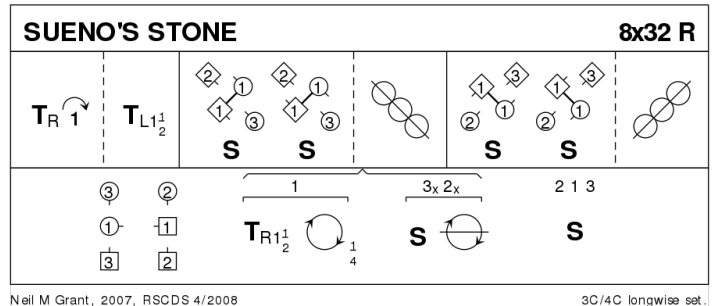

11 LES REMPARTS DE SÉVILLE J32 · 3/4L

Aliénor Latour: RSCDS 50 2 · Crib: MiniCribs · Diagram: Keith Rose's Diagrams

- 1-8** 1s set, cast (2s step up bars 3-4), 1s dance 1/2 Figs 8, 1L round 2s, 1M round 3s
- 9-16** 1s turn LH to face 1st corners & dance set to corners & partner ('Hello-Goodbye') to end 1M between 2s facing down, 1L between 3s facing up
- 17-24** 2s+1s+3s Set+Link, all set, all cross RH
- 25-32** 2s+1s+3s circle 6H round & back

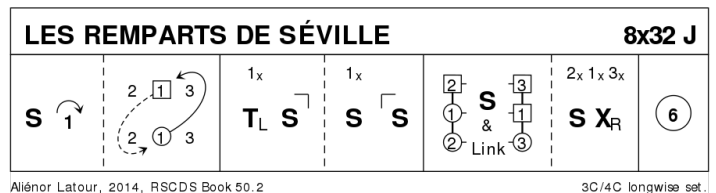

12 THE BRAES OF BREADALBANE S32 · 3/4L

Skillern: RSCDS XXI 7 · Crib: MiniCribs · Diagram: Keith Rose's Diagrams

- 1-8** 1s turn RH cast 1 place, turn LH & 1L casts up as 1M casts down to form lines of 3 across facing each other
- 9-16** 1L+2s & 1M+3s set twice then 1s cast back to 2nd places & turn RH ending on own sides
- 17-24** 2s+1s+3s set twice & turn partners 2H
- 25-32** 2s+1s dance R&L

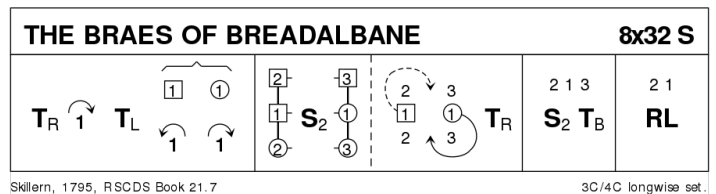

13 A TRIP TO THE DRAKENSBERG

J40 · 3/4L

Barbara J. Rendle-Braime: RSCDS XXXVIII 8 · Crib: MiniCribbs · Diagram: Keith Rose's Diagrams

- 1-8 1s set, cast 2 places & dance up to top (end with 2s stepping in below 1s)
- 9-16 1s+2s dance Poussette (end with 1s facing 1st corners)
- 17-24 1s dance 1/2 diagonal reel of 4 with 1st corners, pass LSh & dance 1/2 reel with 2nd corners (1s end 2nd place opposite side)
- 25-32 3M+1M+2M petronella turn into centre & set **while** 3L+1L+2L set & petronella turn into centre, all turn partners RH (end in Allemande hold)
- 33-40 3s+1s+2s dance Allemande

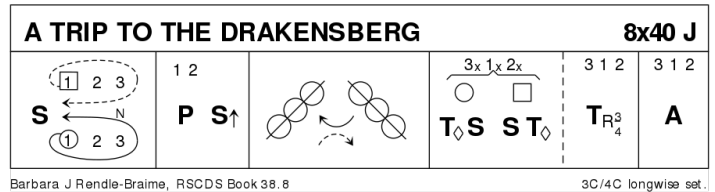

14 BROADFORD BAY

R32 · 3/4L

Anne Grant: The Leaflet Dances with Music · Crib: MiniCribbs · Diagram: Keith Rose's Diagrams

- 1-8 1s followed by 2s dance down the middle, cast up round 3s on own sides, dance in & up to top, 1s casting to 2nd place
- 9-16 2s+1s+3s dance Grand Chain (2M & 1L end facing out)
- 17-24 2L+1M turn RH 1.1/2 & dance 1/2 way round clockwise **while** 2M+1L dance 1/2 way round anticlockwise & turn LH 1.1/4 times to end facing partners
- 25-32 2s+1s dance diagonal reel of 4 ending on own sides with 1s in 2nd place. 2 1 3

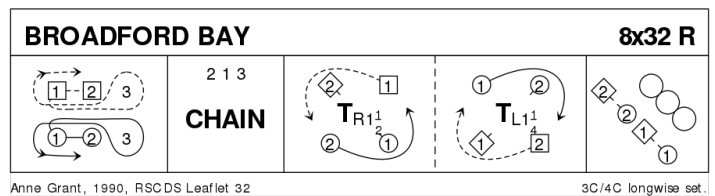

15 BOUNDARY COTTAGE

S32 · 4/4L

Mervyn C Short: Imperial Book of Scottish Country Dances - Volumes 4, 5 and More · Crib: E-cribs · Diagram: Keith Rose's Diagrams

3c & 4c start on opp sides

- 1-- 1c+2c & 3c+4c set | 1M+2W turn BH 3/4 to 2M/1W pl as 2M & 1W cast clw one **while{2}** 3c & 4c dance a symmetric pattern ; 2c+1c & 4c+3c Circle4 L (2,1,4x,3x)
- 9-- 2M+1M & 2W+1W & 4M+3M & 4W+3W change places BH | 1/2 parallel Reels4 | same persons change places BH (3x,4x,1,2)
- 17-- All M pass P Lsh | cast L to exchanged places ; all W pass opp M Rsh | cast R to exchanged places (1x,2x,3,4)
- 25-- 1c+2c & 3c+4c 1/2 RHA (to 2,1,4x,3x) | 1c & 4c 1/2 Fig8 LHJ up/dn (to 2,1x,4,3x) | 1M+4W & 1W+4M change places RH (2,4,1x,3x)

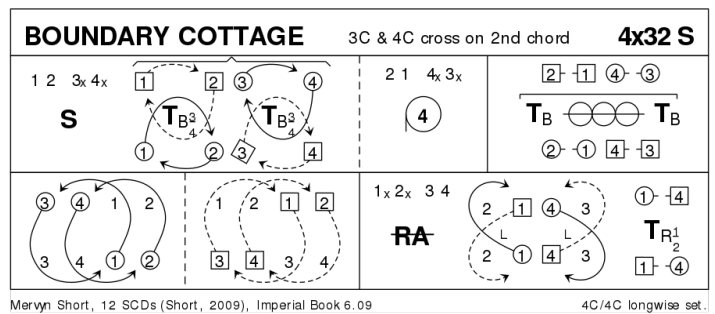

16 QUARRIES' JIG J32 · 3/4L

Kent W Smith: RSCDS XXXVI 3 · Crib: MiniCrib · Diagram: Keith Rose's Diagrams

- 1-8** 1s set, cast 1 place & dance round 1st corners passing corners LSh
- 9-16** 1s dance reels of 3 across (1st Man with 2s & 1st Lady with 3s), 1s turn LH to face 1st corners
- 17-18** Centre dancers change with 1st corners RH **while** 2nd corners set
- 19-20** 1st corners (in centre) change places LH **while** new 1st & 2nd corners dance clockwise round to next corner place
- 21-24** Repeat the Fig in bars 17-20 from new places
- 25-32** Repeat 17-20 from new places, 1s end by turning LH to 2nd place on opposite sides, 2s+1s+3s set on sides & 1s cross back RH

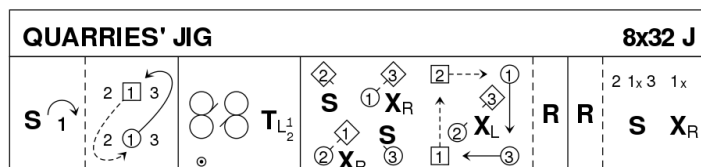

Kent W Smith, RSCDS Book 36.3

3C/4C longwise set.

17 CITY OF BELFAST S32 · 3/3L

Lucy Mulholland: RSCDS XLVIII 6 · Crib: MiniCrib · Diagram: Keith Rose's Diagrams

- 1-8** 1s dance 1/2 Fig of 8 round 2s, 1L+2M turn RH 1.1/4 times **while** 1M+2L turn LH 1.1/4 times & 1s end BtoB facing opp sides
- 9-16** 1s+2s dance reel of 4 across & 2s end in 1st places **while** 1s pass LSh to face 1st corners
- 17-24** 1s set to 1st corner & 2nd corner ending (turning to right) between corners, all set & 1s cross RH
- 25-32** 1s+3s dance Espagnole:
25-26 1s+3s cross (Ladies lead across RH passing between Men) with Ladies changing places RH
27-28 1s+3s cross back (Men lead across RH between Ladies) with Men changing places RH
29-32 3s turn RH as 1s turn LH to end 2 3 1

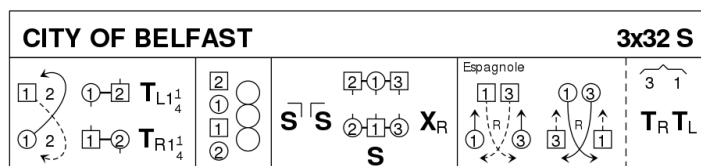

Lucy Mulholland, 2007, Belfast Diamond Jubilee Book, RSCDS Book 48.6

3C/3C longwise set.

18 SLEEPY MAGGIE R32 · 3/4L

Alexander Bowman: RSCDS XI 5 · Crib: MiniCrib · Diagram: Keith Rose's Diagrams

- 1-8** 1s+2s circle 4H round to left, 1s set & cast 1 place
- 9-16** 1s+3s dance RH across & LH back (1s end facing 1st corners)
- 17-24** 1s set & turn 1st corners, set & turn 2nd corners
- 25-32** 1s dance reels of 3 on opposite sides giving LSh to 1st corners & cross to places

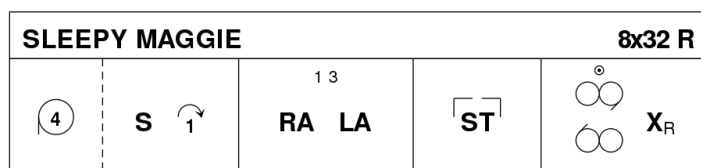

Alexander Bowman, 1755, RSCDS Book 11.5

3C/4C longwise set.