

RSCDS Paris Branch - Bal du 14 mars 2020

1 THE DUKE OF ATHOLL'S REEL J32 · 2/4L

Skillern: RSCDS XVI 3 · Crib: E-cribs · Diagram: Keith Rose's Diagrams

- 1- 1c+2c set, ½ RHA ; set, ½ LHA
- 9- 1M+2W set advancing, turn RH ;
1W+2M repeat
- 17- 1c cross RH, cast off (2c up) ; ½ Fig8
up round 2c
- 25- 2c+1c R&L.

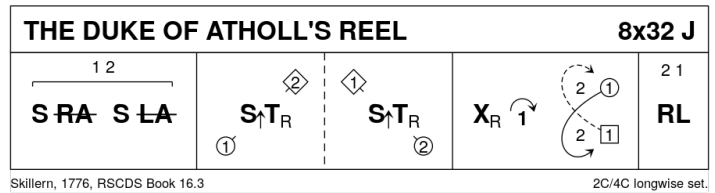

2 THE ENGINE ROOM R32 · 3/4L

Thomas, Gary & Wallace, Ron: The San Andreas Collection · Crib: E-cribs · Diagram: Keith Rose's Diagrams

- 1- 1c+2c+3c set | Mirror Reels3{6} on
own side, 2c start out and up
- 9- 1c dance BtoB ; cast off (2c up) | cross
RH and face out (2,1x,3)
- 17- 1cnrs dance BtoB diagonally **while**{4}
1c cast R to meet in centre and stand
BtoB, M facing down, W up ; All dance 4 bars of DTr, finish 1M facing up, 1W down
- 25- 2cnrs dance BtoB diagonally **while**{4} 1c cast R to meet in centre and stand BtoB, facing
opposite side ; All dance 4 bars of DTr, finish (2,1,3)

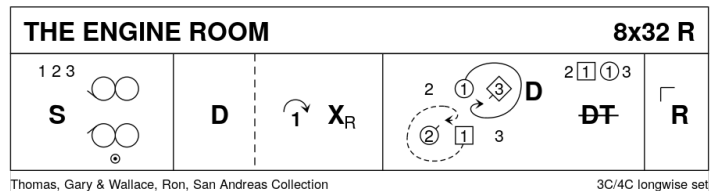

3 THE BRAES OF TULLIEMET S32 · 3/4L

RSCDS VII 12 · Crib: E-cribs · Diagram: Keith Rose's Diagrams

- 1- 1c set | cast off (2c up) ; cross RH |
cast off (3c up) (2,3,1x)
- 9- 3c+1c circle4 L, to sidelines ; 1c dance
to the top | cast off to face 1cnrs (3c
down)
- 17- 1c set to and turn corners
- 25- Reels3{6} on the sides (Lsh to 1c) | 1c cross over (2,1,3)

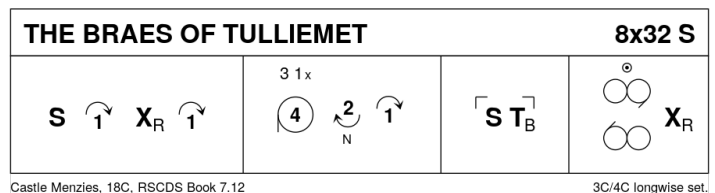

4 MISS MARGARET HILL J32 · 3/4L

Miss Milligan's Miscellany of Scottish Country Dances · Crib: MiniCribs · Diagram: Keith Rose's Diagrams

- 1-8 1L sets advcg to 2M & turns 3M 2H to
end b'tw'n 2M+3M, 1M sets advcg to
2L & turns 3L 2H & ends facing down
with 1L (who crosses) on left
- 9-16 1s lead down the middle & back
- 17-24 1s+2s dance Allemande 1s end facing
1st corners
- 25-32 1s turn 1st corners RH, partner LH, 2nd corner RH & partner LH to end in 2nd places own side

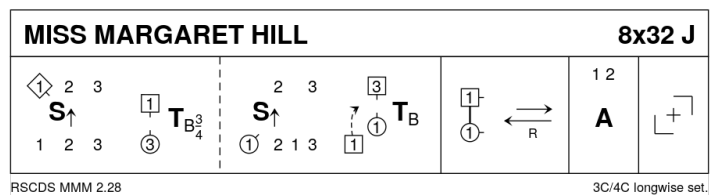

5 JOHN OF BON ACCORD R32 · 3/4L

Roy Goldring: RSCDS XXXIII 5 · Crib: E-cribs · Diagram: Keith Rose's Diagrams

- 1-16 4 progressive ½Reels3 across, as follows: 1c+2W (1c start Rsh to P) ; 1c+2M (start Lsh) ; 1c+3W (Rsh) ; 1c+3M (Lsh), 1c finish in 3pl a bit in from the sidelines (2c & 3c finish their reels in 1plx and 2plx)

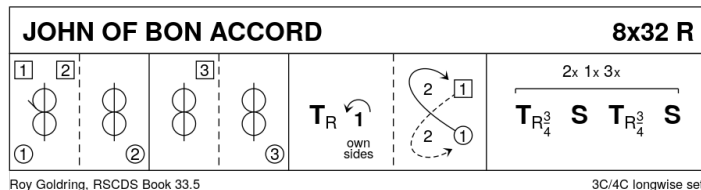

- 17- 1c turn RH, cast up one place on own sides (3c down) ; 1c ½ Fig8 round 2c (2x, 1x, 3x)
 25- All turn P ¾ RH to face P along the midline | All Set retaining RHJ ; all turn P ¾ RH | All Set (2,1,3)

6 THE ROSE GARDEN S24 · 2/4L

Kathy Wendell: San Francisco Collection Volume 2 · Crib: E-cribs · Diagram: Keith Rose's Diagrams

- 1-- 1c+2c lead down | lead up ; 1c cast off as 2c leads up and casts into 1pl | 2c+1c cross RH (2x, 1x)
 9-- 2c+1c set passing P Lsh and twirl R to face P, turn BH to own side facing other cpl ; repeat up/dn along sidelines (to 1,2)
 17-- 1c+2c circle4 L ; ½Poussette (2,1)

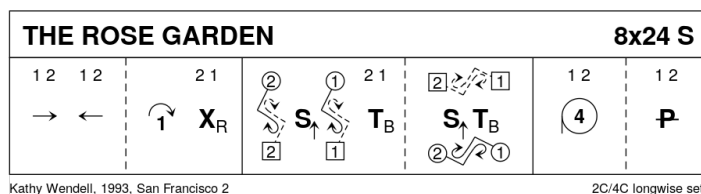

7 WHAT A BEAU MY GRANNY WAS R32 · 3/4L

Longman & Broderip (18C): RSCDS XIV 9 · Crib: E-cribs · Diagram: Keith Rose's Diagrams

- 1- 1W+2W+3W set twice, circle3 L **while** {} the 1M followed by 2M+3M chase round them clw, all to places
 9- Repeat bars 1 - 8 the M set and circle3 L **while** {} the W dance cclw round the men (1W leading), 1c+2c finish ready for
 17- 1c+2c Poussette
 25- 1c+3c R&L

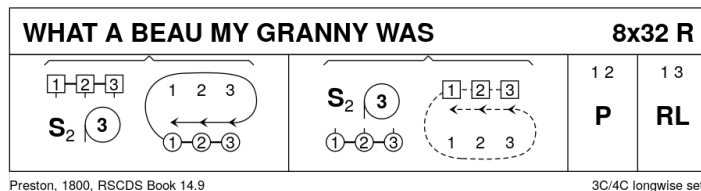

Note: for [9-16] neither the instructions nor any notes say that 1W leads cclw, 3W leading clw is also possible

INTERVAL

8 THE SAILOR R32 · 3/4L

RSCDS XXIV 4 · Crib: E-cribs · Diagram: Keith Rose's Diagrams

- 1- 1c cross down RH (2c up) to 2plx and BiL with cnrs ; 1c cast R into lines across | all set
- 9- All Reels3 across, Rsh to 1cnr, finishing (2,1x,3)
- 17- 1c lead down | lead to the top ; cross and cast to (2,1,3)
- 25- 2c+1c R&L.

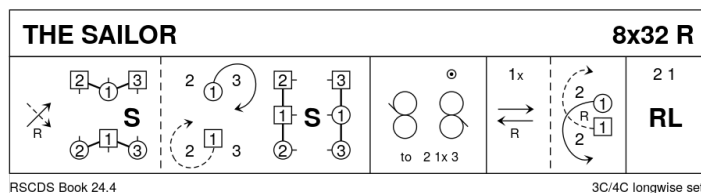

Note: [3-4] is NOT in DT_r position.

9 IT'S ABOUT TIME S32 · 3/4L

Elaine Brunken: Moments in Time · Crib: E-cribs · Diagram: Keith Rose's Diagrams

- 1- 1c+2c Pousette
- 9- 1c+2c S&Link ; 2c+1c Circle4 L (2,1,3)
- 17- 1c set to P and cnr (1c set to P and face 4cnr, set to 4cnr and face P up/dn) ; set to P (no adv.) | turn BH to face 1cnr
- 25- Corners Pass and Turn. (2,1,3)

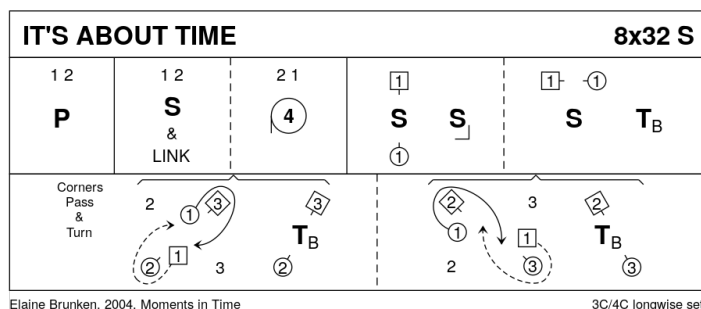

10 MAJOR IAN STEWART J32 · 3/4L

John Drewry: RSCDS XXXV 4 · Crib: E-cribs · Diagram: Keith Rose's Diagrams

- 1- 1c+2c turn RH ½ into | ½ RHA into ; 2c+1c turn RH, 2c finish facing out (2,1,3)
- 9- Opposing Reels3 on own sides (1c inwards, Rsh to 4cnr) 1c finish facing 1cnr, 2c+3c finish with loops
- 17- SetH&G to (2,1,3)
- 25- Circle6 L {3}, cross R foot over L and chase back cclw to (2,1,3)

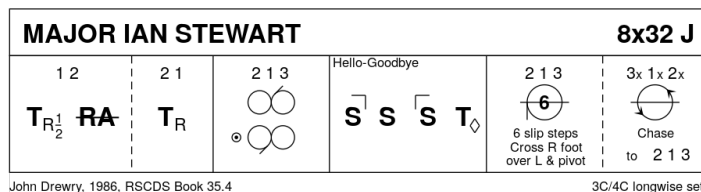

11 ERIC'S JUBILEE R32 · 4/4L

Roy Goldring: 15 Social Dances · Crib: E-cribs · Diagram: Keith Rose's Diagrams

- 1- 1c+3c long cast down (2c+4c up) ; cross RH | cast up to the middle, forming lines of 4 facing down
- 9- All dance down the middle, turn R about and dance up 1c+3c finish facing up.
- 17- 1c with 3c following cast off to (2,3x,4,1x), end couples facing middle couples ; All set up/down | all set to P
- 25- 2c+3c & 4c+1c RHA ; 3c+1c lead up, cross and cast off to (2,3,4,1).

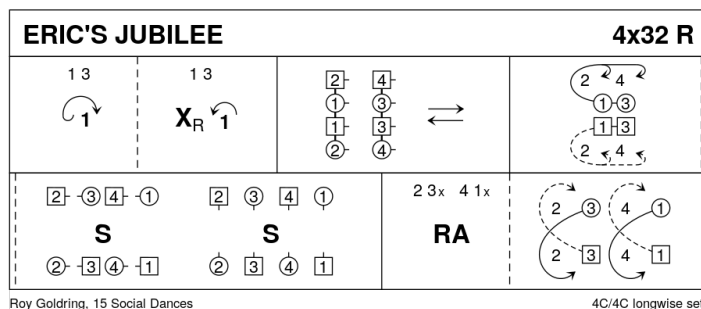

12 MISS GIBSON'S STRATHSPEY S32 · 3/4L

Derek Haynes: The Leaflet Dances with Music · Crib: E-cribs · Diagram: Keith Rose's Diagrams

- 1- 1c+2c set | turn BH ; circle4 L
- 9- 1c+2c Knot, 1c finish facing 1cnrs
- 17- Turn CPCP, with final wide 3/4 LH turn into
- 25- Teapots R and L (1M+3c & 1W+2c RHA, 1c pass Rsh, cnrs not to sidelines ; 1M+2c & 1W+3c LHA) (2,1,3)

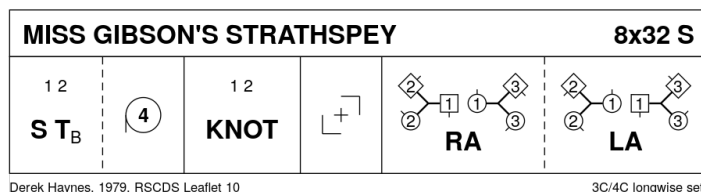

13 RORY O'MORE J32 · 2/4L

RSCDS I 9 · Crib: E-cribs · Diagram: Keith Rose's Diagrams

- 1- 1c+2c A&R ; all cross NHJ, the M making the arch | keeping hands joined change places on the sides, 2c passing outside as 1c twirls under the joined hands (2x,1x)
- 9- 2c+1c A&R ; all cross NHJ, the W making the arch | change places on the sides as before, 2c again passing outside (1,2)
- 17- 1c lead down the middle and up
- 25- 1c+2c Pousette (2,1)

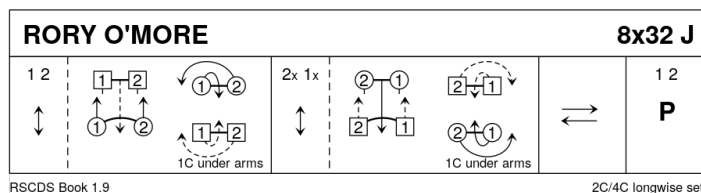

Option: on [8] and [16] the turns under joined hands may be omitted.

14 THE REEL OF THE 51ST DIVISION R32 · 3/4L

James Edward McCartney Atkinson: RSCDS XIII 10 · Crib: E-cribs · Diagram: Keith Rose's Diagrams

- 1- 1c set | cast off two places (2c up) and lead up to 1cnrs
- 9- 1c set to 1cnr | turn 1cnr RH and join LH in the middle ; BiL | turn 1¼ LH to 2cnrs
- 17- Repeat with 2cnrs | cross to (2,1,3)
- 25- 2c+1c+3c circle6 and back.

THE REEL OF THE 51st DIVISION			8x32 R
S	S T _R B T _L ^{1/4}	S T _R B T _L	2 1 3 ⊙ 6 ⊙

Jimmy Atkinson & Peter Oliver, 1940, RSCDS Book 13.10

3C/4C longwise set.