

RSCDS Paris Branch - Bal du 14 mai 2022

Première partie

1 MRS STEWART'S JIG J32 · 3/4L

Frans Ligtmans: RSCDS XXXV 1 · Crib: E-cribs · Diagram: Keith Rose's Diagrams

- 1-- 1c set | 1W casts, 1M following, round 3W, 1W dances up round 3M and 1M dances up the middle, 1c face 3c (2c up on 7-8) (2,1x,3)
- 9-- 2c+1c+3c G-Chain (2c cross), 2M+1M finish facing out
- 17-- 2c+1c L-Chain
- 25-- 2c+1c+3c A&R ; 1c turn RH 1½ to (2,1,3)

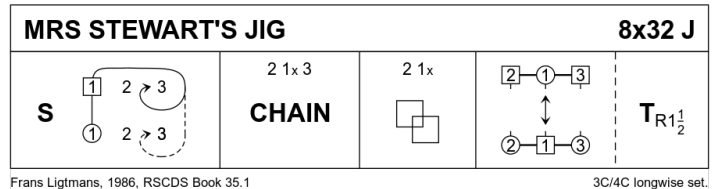

2 THE COUNTESS OF DUNMORE'S REEL R32 · 3/4L

Deirdre MacCuish Bark: RSCDS XLIX 12 · Crib: E-cribs · Diagram: Keith Rose's Diagrams

- 1-- 1c set | dance down (2c up) ; cast up round 3c | set advancing to face 1cnr
- 9-- 1c turn 1cnr RH, pass Rsh; turn 2cns RH, pass Rsh to face out in 2pl (cnrs dance for {4}) (2,1,3)
- 17-- [3C Chain Progression] 1c cast ¼ clw round set **while** 2c & 3c Turn RH ¾ | 2M+3W turn LH 1½ **while**{4} the others promenade clw ½ round set | 3c+2c turn RH ¾ **while** 1c dance clw to 2pl (3,1,2)
- 25-- all chase ½ way clw ; set | cross RH (2,1,3)

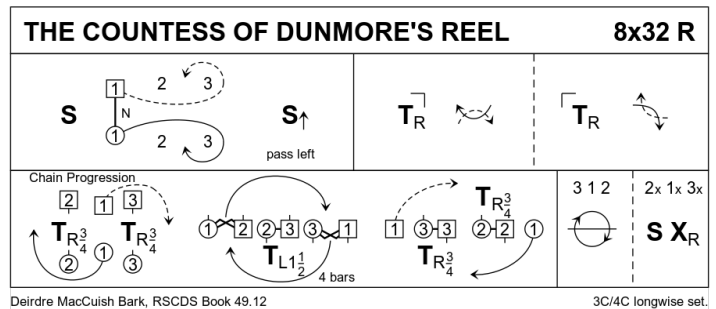

3C Chain Progression was earlier known as Chaperoned Chain Progression

3 MARGARET PARKER'S STRATHSPEY S32 · 3/4L

John Drewry: RSCDS XXXI 3 · Crib: E-cribs · Diagram: Keith Rose's Diagrams

- 1-- 1c lead down crossing between 2c, cast off round 3c and NHJ up the middle ; 1W LHA (and 1M RHA) with 1cnr+2cnr, 1c finish in 1plx facing out (1x,2,3)
- 9-- 1c+2c change places on sides EH | 1c turn BH ¾ to finish facing down, 1M just above 2c and 1W (swivel R) just above 3c ; 1M+2c & 1W+3c Circle3 left, into lines across facing down
- 17-- Lines of 3 dance down the middle, swivel R, dance up, finish line facing line
- 25-- Lines set | cross RH ; set, 2c+3c cross back RH **while**{2} 1c cast to own side (2,1,3)

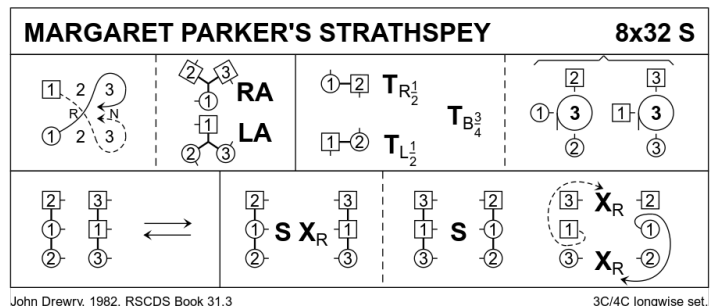

4 THE MAID OF THE MILL J40 · 3/4L

RSCDS XXI 11 · Crib: E-cribs · Diagram: Keith Rose's Diagrams

- 1- 1c turn RH | cast off 2 (2c+3c up) ; turn LH | cast back (2c+3c down)
- 9- Mirror Reels3 on opposite sides, 1c crossing down to start, 1c finish facing 1cnr and 2c in 1pl
- 17- 1c set to 1cnr | to 2cnr, finish on sides (2,1x,3) ; 1½ RH turn to 2pl (2,1,3)
- 25- 1M+3c & 1W+2c ½ Lsh Reel3 across ; 1c turn LH to 2plx
- 33- 1M+3c & 1W+2c ½ Rsh Reel3 across ; 1c turn RH to (2,1,3)

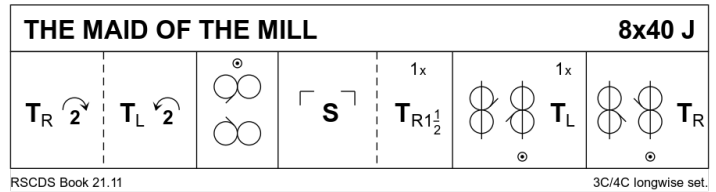

5 KARIN'S STRATHSPEY S32 · 3/4L

Derek Haynes: A Third Book of Graded Scottish Country Dances · Crib: E-cribs · Diagram: Keith Rose's Diagrams

- 1- 1c+2c the Knot
- 9- 1c set advancing towards 1cnrs, turn corner BH ; open into circle4 L, ending with 1cnrs in places and 1W+2c & 1M+3c forming lines across
- 17- 1c repeat with 2cnrs, to finish between corners
- 25- Lsh Reels3{6} on opposite sides with cnrs | 1c cross to own side

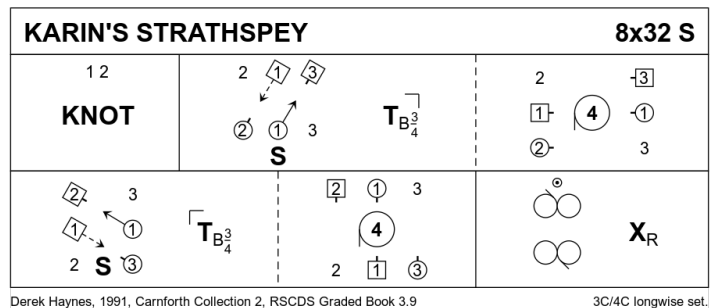

6 STARLIGHT R32 · 3/4L

Ed Abdill: RSCDS XLIV 1 · Crib: E-cribs · Diagram: Keith Rose's Diagrams

- 1- 1c cross RH | cast (2c up) ; 1c petronella into DTr position | all set as in DTr
- 9- 1c dance out and cast R round 1cnr to between end couple **while{4}** 2c+3c A&R diagonally ; 1c petronella into DTr position (BtoB, M below W) | all set as in DTr
- 17- 1c dances between end couple and cast R round 4cnr **while{4}** 2c+3c A&R diagonally (to 2,1,3) ; Teapots R (1c RHA with couple on R), finish facing 1cnr
- 25- SetH&G (2,1,3)

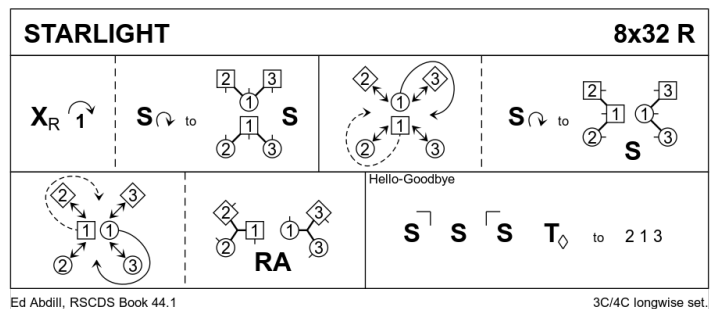

Deuxième partie

7 CHRISTINE M PHILLIPS J32 · 3/4L

John Brenchley: RSCDS XLVI 1 · Crib: E-cribs · Diagram: Keith Rose's Diagrams

- 1- 1c set adv. and join RH | lead down (2c up) , cross below 3c, cast up and turn LH to face 1c nr
- 9- 1c+1cnrs ½ Reel4 ; turn 3c nr (pstn) RH | turn P LH to face 2c nr
- 17- 1c+2cnrs ½ Reel4 ; turn 4c nr (pstn) RH | turn P LH into
- 25- 3c+1M & 1W+2c RHA ; 2c+3c chase clw ½ round **while**{4} 1c turn LH to (2,1,3)

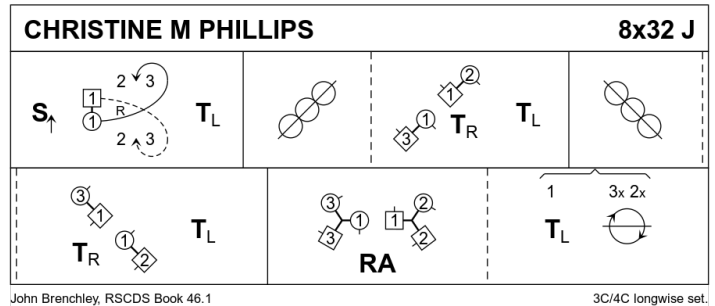

8 THE CASTLE OF MEY R32 · 3/4L

John Walton: QE Diamond Jubilee Dances · Crib: E-cribs · Diagram: Keith Rose's Diagrams

- 1- Inveran Reels3 on the sides, 1c crossing down to start (1,2,3)
- 9- 1c+2c DblFig8, 1c cross down to start
- 17- 1c lead down the middle and up, finishing for
- 25- 1c+2c Poussette

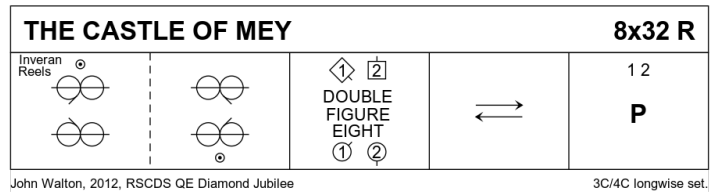

9 BARBARA'S STRATHSPEY S32 · 3/4L

Sue McKinnell: RSCDS XLVI 4 · Crib: E-cribs · Diagram: Keith Rose's Diagrams

- 1- 1c set | cast (2c up) ; ½ Fig8 L (2,1x,3)
- 9- All set | 1c cross Rsh ; 1c+3c nr turn RH 1½ (to 1,2,3 on M side, 2,3,1 on W side)
- 17- 3C Bourrel: 2W+3M chase cclw half round to midline **while**{4} 1M+3W & 2M+1W set adv | turn BH ¾ and pivot R, all facing P on midline (3,1,2) ; All set | All C turn BH ¾ to sidelines
- 25- All chase clw ½ round ; all turn P RH ½ and twirl R to (2,1,3)

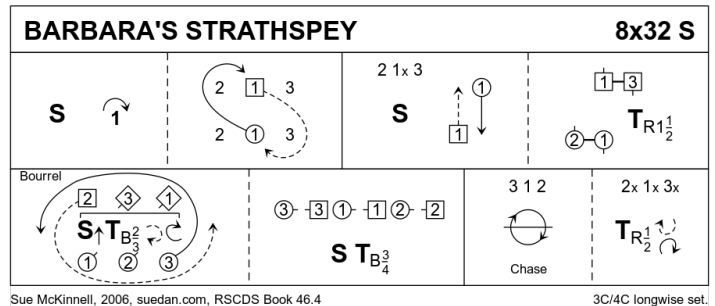

10 THE BEES OF MAGGIEKNOCKATER

J32 · 4/4L

John Drewry: *Thirty Popular Dances, Volume Two* · Crib: *E-cribs* · Diagram: *Keith Rose's Diagrams*

- 1- 1c cross RH | cast off (2c up) ; 1c+3c RHA, finish as pairs 1M+3W & 3M+1W facing out on W/M side in promhold
- 9- Pairs+ 2c+4c Rsh ½Reels3 on sides ; pairs meet & take P in promhold for Lsh ½Reels3 on sides
- 17- Meet and repeat (as pairs Rsh ½Reels3 ; with P Lsh ½Reels3)
- 25- 1c (passing inside) turn 3c 1½ Easy Hand ; 1c cross and passing inside turn 4c EH 1½ (to 2,3,4,1)

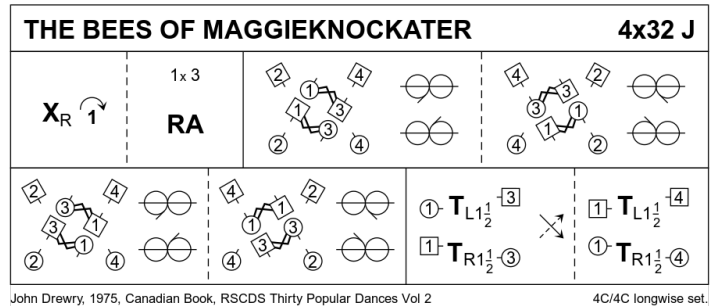

11 THE MINISTER ON THE LOCH

S32 · 3/3L

Roy Goldring: *Magazine Dances 2005-2009* · Crib: *E-cribs* · Diagram: *Keith Rose's Diagrams*

- 1- 1c+2c Pousette
- 9- 1c dance down 2 places, turn BH ; dance up 2 places, turn BH, open upwards and face out
- 17- 1c+3c DbIFig8 round 2c, 1c casting, 3c crossing up to begin, 1c finish facing out for
- 25- 1W+2W & 1M+2M turn EH 1½ ; 1c+3c repeat (2,3,1)

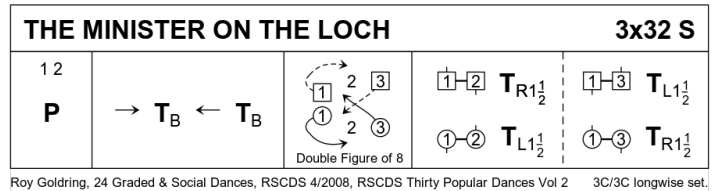

12 TRIP TO TIMBER RIDGE

R32 · 3/4L

Linda Henderson: *RSCDS LII 12* · Crib: *E-cribs* · Diagram: *Keith Rose's Diagrams*

- 1-- 1c turn RH | cast (2c up) ; 1W+2c & 1M+3c RHA, 1c facing 1cnrs at end
- 9-- Corners Pass and Turn, on [16] 1c pull Rsh back to finish BtoB in centre facing opposite side
- 17-- DTr, on [23-24] 1c Petronella turn to 2pl (2,1,3)
- 25-- Circle6 and back

