

2023-05-13-Bal avec Musiciens Paris

1 THE FERRY LOUPER J32 · 3/4L

Roy Goldring: *Graded and Social Dances 1 - 24 Dances* · Crib: *E-cribs* · Diagram: *Keith Rose's Diagrams*

- 1- 1c+2c+3c chase clw once round to places
- 9- 1c+2c RHA, LHA
- 17- 1c cast down 2, dance up 2, cast to 2pl (2c up)
- 25- 2c+1c+3c A&R, all turn RH

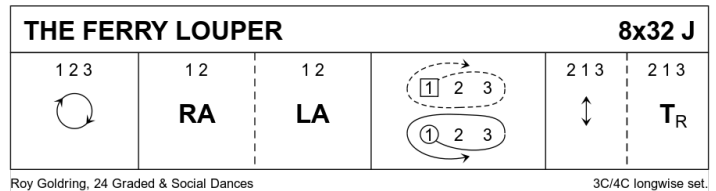

2 GLASTONBURY TOR R32 · 3/4L

Duncan Brown: *RSCDS XLVII 11* · Crib: *E-cribs* · Diagram: *Keith Rose's Diagrams*

- 1- 1c+2c set | ½ RHA ; 1c+3c set | ½ LHA (2x,3x,1)
- 9- 1c set | cross RH ; cast up one (3c down) | turn LH to face 1cnr (pos)
- 17- ½ diag Reel4 with 1cnrs, pass Lsh ; ½ diag Reel4 with 2cnrs, 1c curve R into facing lines of 3 across, 1M at top, 1W at bottom
- 25- All S&Link3 ; 1c turn RH 1½ **while{4}** cnrs chase clw ½ round (2,1,3)

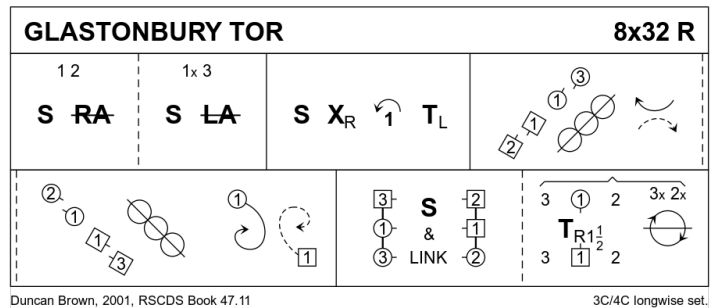

3 CUILLINS OF SKYE S32 · 3/4L

Roy Goldring: *Four Scottish Country Dances 1978* · Crib: *E-cribs* · Diagram: *Keith Rose's Diagrams*

- 1- 1c cross RH **while{2}** 2c (starting in) +3c change place on the sides EH | Mirror Reels3{6} on the sides, 3c (in 2pl) starting in and up, 1c ends facing out (1x,3,2)
- 9- 1c cast off **while{2}** 3c dance to top giving NH | 1c ½ Fig8 L (1W up, 1M down) | 1c 1¼ turn LH (1M now below 1W)
- 17- 3c+1W & 1M+2c RHA (Teapots R), to sidelines ; 3c+1M & 1W+2c LHA (3,1,2)
- 25- 3c+1c+2c the Knot (2,1,3)

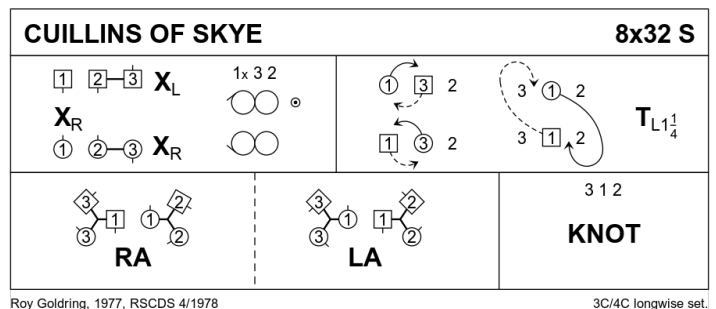

4 THE HAZEL TREE J32 · 3/4L

John Drewry: *The Brodie Book* · Crib: *E-cribs* · Diagram: *Keith Rose's Diagrams*

- 1- 1c+2c Espagnole, 1c finishing facing 1cnr
- 9- 1c turn 1cnr RH, pass Rsh ; turn 3cnr LH, pass Lsh (cnrs dance for {4})
- 17- Turn 2cnr RH, pass Rsh ; turn 4cnr LH, pass Lsh to 2plx side by side facing down
- 25- Lead LHJ between 3c, cross and cast to 2pl ; All C turn RH

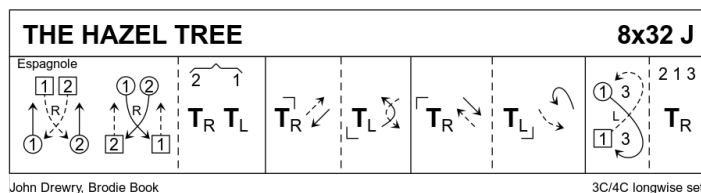

Espagnole: both W lead RHJ to M side, cross and cast back to exchanged places **while{4}** Men cross to W side, lead RHJ back to M side and cross to exchanged places ; all turn P EH (2,1)

5 FIFE NESS R32 · 3/4L

Mary Shoolbraid Brandon: *Four Scottish Country Dances 1978* · Crib: *E-cribs* · Diagram: *Keith Rose's Diagrams*

- 1- 1c ½ RH turn to promhold, dance between 3c ; cross LH (2c up) and cast up to (2,1,3)
- 9- 2M+1W+3M set advancing to form triangle NHJ {2}, set retiring, advancing, retiring **while{8}** 2W+1M+3W stand {2}, set advancing likewise, retiring, advancing
- 17- 1c in promhold +2W+3W Lsh ½Reel3 in centre of set ;
1c+(2W+3M)+(3W+2M) all in promhold ½Reel3
- 25- 1c+2M+3M ½Reel3 (finish 2x,1x,3x) ; all set and cross RH

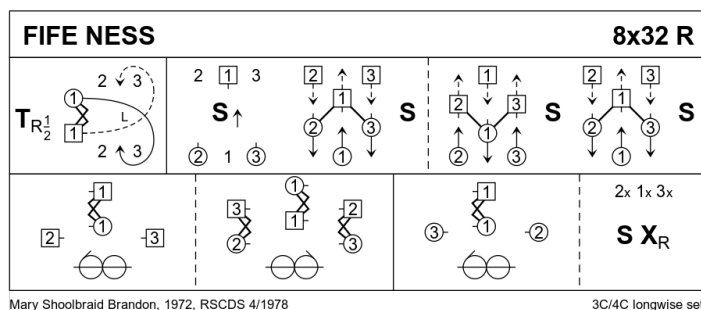

6 BRUNETTE D'ECOSSE S32 · 3/4L

Ann Dix: *Reel Friends Book 2* · Crib: *E-cribs* · Diagram: *Keith Rose's Diagrams*

- 1- 1c+2c S&Link ; 2c+1c+3c set, advancing on 2nd step | Turn P BH into
- 9- 3C Allemande, 1c finish facing 1cnr (3,1,2)
- 17- 1c set to and turn 1cnr BH ; repeat with 2cnr, 1c finish Lsh touching in middle facing own side
- 25- All (1c merging in) chase ½ clw ; all C turn BH 1½ (to 2,1,3)

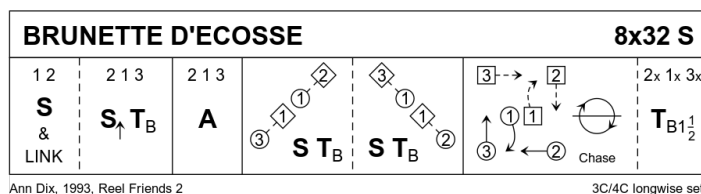

7 THE BUCHAN EIGHTSOME REEL R400 · 4S

RSCDS XXI 8 · Crib: E-cribs · Diagram: Keith Rose's Diagrams

Part A

- 1- Circle 8 and back
- 9- ½ G-Chain, 2 bars/H, (to 3,4,1,2)
- 17- All RHA, W inside, NHJ with P (3,4,1,2)
- 25- ½ G-Chain (to 1,2,3,4)
- 33- All LHA, M inside, NHJ with P (1,2,3,4)

Part B

- 1- 1W sets alone inside, others Circle 7 and back
- 9- 1W sets to P | turn R arm (elbow grip, M raise the free arm) ; 1W+opposite M (3M) set, turn L arm and face M to the L (4M)
- 17- 1W+M (=4M) set, turn L arm ; 1W+opposite M (2M) set, turn R arm and face R (Partner)
- 25- 1W+P+M opposite (1M+3M) Reel 3, start Rsh to P, at end face L (M raise both arms)
- 33- 1W+M on the sides (4M+2M) Reel 3, start Lsh to 4M

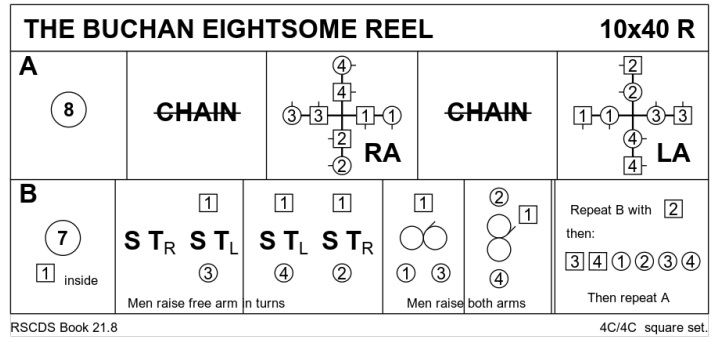

Dance A, then B with inside in turn 1W, 2W, 3W, 4W, then 1M, 2M, 3M, 4M (who dance with the W), finish with A

Memorize: centre dancer Turns R,L,L,R, then Reels Rsh to P, Lsh across

BREAK

8 LE TRÈFLE À QUATRE FEUILLES J32 · 3/4L

Anne Dejean: The Walnut Book Vol 2 · Crib: E-cribs · Diagram: Keith Rose's Diagrams

- 1-- 1c turn RH ; cast off (2c up) | turn RH ½ to face 1cnrs
- 9-- Corners Pass and Turn
- 17-- Repeat [9-16] with 3cnrs then 4cnrs (2,1,3)
- 25-- Circle 6 and back

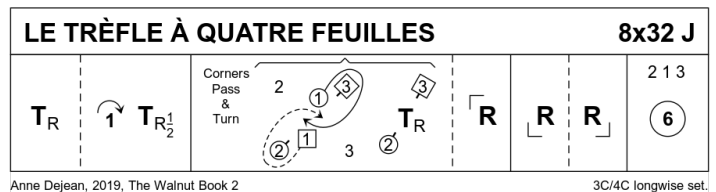

9 THE IRISH ROVER R32 · 3/4L

James B Cosh: Twenty Two SCD · Crib: E-cribs · Diagram: Keith Rose's Diagrams

- 1- 1c dance through 3c (2c up) and cast up ; 2c+1W & 1M+3c RHA, 1c finish facing 1cnrs.
- 9- 1c+1cnrs ½ Reel 4, pass Lsh ; ½ Reel 4 with 2cnrs, fast ¾ LH turn in the centre
- 17- 1W+3c (at top) & 1M+2c Reels 3 across (Lsh to 1c nr pos), (to 3x,1,2x)
- 25- diagonal R&L (1M down, 1W up) (2,1,3)

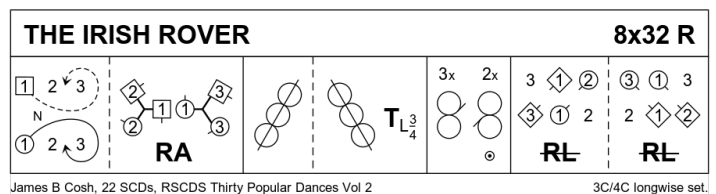

10 THE LIBRARY OF BIRMINGHAM

S40 · 4/4L

Kenneth Reid: RSCDS XLIX 9 · Crib: E-cribs · Diagram: Keith Rose's Diagrams

- 1-- 1c+2c & 3c+4c dance the Rose Progression:
1L+2M change places RH | cast to R ;
turn BH ½ & twirl on 1 diagonal
while(8)
1M+2L set | turn BH ½ & twirl on 1
diagonal | cross to own side (2,1,4,3)
- 9-- All chase clw ½ round ; all set | all turn
RH ½ into
- 17-- 3c+4c & 1c+2c 6 bars of Allemande |
all turn LH ½ to (4x,3x,2x,1x)
- 25-- All chase cclw ½ round ; 1c+2c and
3c+4c circle4 R (1,2,3,4)
- 33-- S&Link4 (All set | dancers on L dance, dancers on R cast, ends moving one place, middles
moving two places) ; 3c+1c and 4c+2c circle4 L (3,1,4,2)

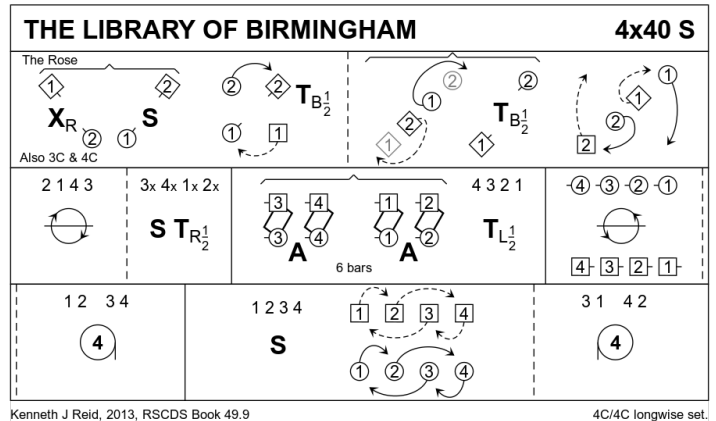

11 THE REEL OF MEY J48 · 3/4L

George Small: RSCDS XXII 1 · Crib: E-cribs · Diagram: Keith Rose's Diagrams

- 1-- 1c cross RH, cast off (2c up) ; 2c+1c
RHA
- 9-- 1c cross LH, cast off (3c up) ; 3c+1c
LHA
- 17-- 1c dance to top, cast off (own side),
pass between 3c and cast up to 1cnr
(3c down)
- 25-- Reel4 with 1cnrs, and dance Rsh round P to face 2cnr
- 33-- Reel4 with 2cnrs, end (2,1,3)
- 41-- All Circle6 and back

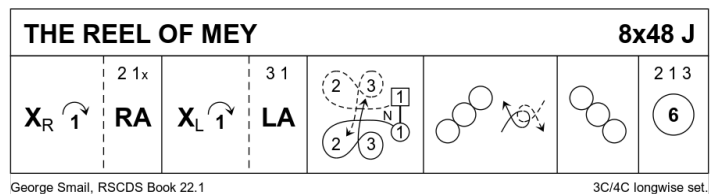

12 KILT SWING R32 · 3/4L

Jamie Berg Gray · Crib: SCDDDB Contributed Cribs & Diagrams · Diagram: Keith Rose's Diagrams

- 1-8 1C turn RH, lead down below 3C; cast
up to 2nd place on own sides, on bars
7-8, set advancing and pull back RS to
end back-to-back facing own sides
- 9-16 Double triangles. 1C finish in the
middle of the set facing up, NHJ, man
with his partner on his right.
- 17-24 2C, 1C, 3C mirror reels of 3 on sides, 1C and 2C continuing the track to finish in original order,
BHJ with partner
- 25-32 1C and 2C poussette.

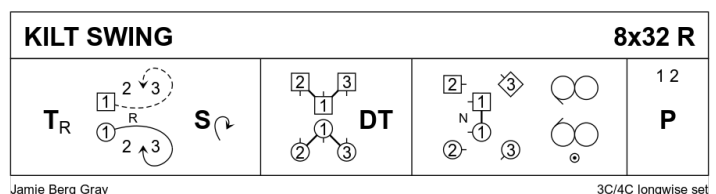

13 ORAGE À LYON S32 · 3/3L

Corinne Hilpert: *Gone Dancing Bk 2* · Crib: *E-cribs* · Diagram: *Keith Rose's Diagrams*

- 1-- 1c set advancing | turn BH ; dance down 2 places (2c+3c up) | turn BH to 3pl (2,3,1)
- 9-- 3c+1c Tourbillon (2,1,3)
- 17-- All chase clw ½ (to 3x,1x,2x) ; turn P RH ½, face P | cast R to exchanged places (3,1,2)
- 25-- 1c+2c Poussette (3,1,2)

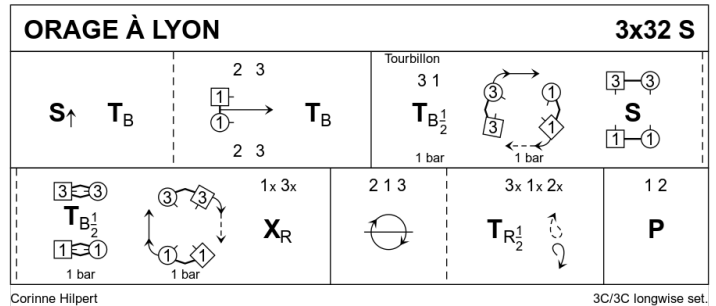

14 DA RAIN DANCIN' R32 · 3/4L

Ron Wallace: *Thirty Popular Dances, Volume Two* · Crib: *E-cribs* · Diagram: *Keith Rose's Diagrams*

- 1-- 1c dance down 2 places and cast up to 2pl (2c up) ; 2c+1c+3c set and cross RH (2x,1x,3x)
- 9-- 1c dance up and cast off one ; 2c+1c+3c set | 2c+3c cross LH **while** {2} 1c turn LH to face 1cnr:
- 17-- 1c set R to 1cnr {1} and L to P {1} | turn ¾ RH ; set R to 2cnr and L up/down to P | turn ¾ RH to 2pl
- 25-- 2c+1c+3c circle6 and back. (2,1,3)

