

RSCDS Paris Branch - Bal du 15 mars 2025

Première partie

1 MRS STEWART'S JIG J32 · 3/4L

Frans Ligtmans: RSCDS XXXV 1 · Crib: E-cribs · Diagram: Keith Rose's Diagrams

- 1- 1c set | 1W casts, 1M following, round 3W, 1W dances up round 3M and 1M dances up the middle, 1c face 3c (2c up on 7-8) (2,1x,3)
- 9- 2c+1c+3c G-Chain (2c cross), 2M+1M finish facing out
- 17- 2c+1c L-Chain
- 25- 2c+1c+3c A&R; 1c turn RH 1½ to (2,1,3)

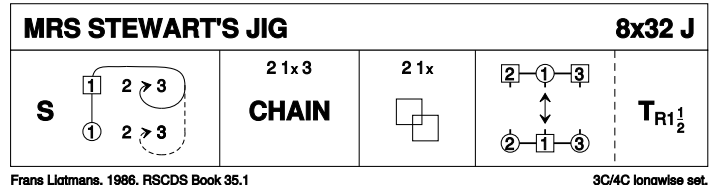

2 STARLIGHT R32 · 3/4L

Ed Abdill: RSCDS XLIV 1 · Crib: E-cribs · Diagram: Keith Rose's Diagrams

- 1- 1c cross RH | cast (2c up); 1c petronella into DTr position | all set as in DTr
- 9- 1c dance out and cast R round 1c nr to between end couple **while(4)** 2c+3c A&R diagonally; 1c petronella into DTr position (BtoB, M below W) | all set as in DTr
- 17- 1c dances between end couple and cast R round 4c nr **while(4)** 2c+3c A&R diagonally (to 2,1,3); Teapots R (1c RHA with couple on R), finish facing 1c nr
- 25- SetH&G (2,1,3)

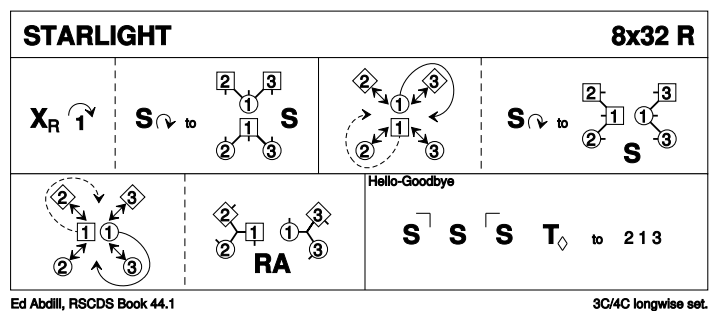

3 SANDS OF MORAR S32 · 3/4L

Barry Priddey: RSCDS XLV 6 · Crib: E-cribs · Diagram: Keith Rose's Diagrams

- 1- 1c Fig8 round 2c, giving hands
- 9- All Mirror Reels3 on own side, 1c starts in, join hands on meeting P
- 17- 1c turn BH | 1c dance to 3pl NHJ **while(4)** 2c+3c continue reel to top and follow behind 1c; 3c+2c+1c set facing down | 1c cast to top, 2c+3c following to finish (1,2,3)
- 25- 1c+2c Tourbillon (1c+2c turn P BH ½, opening out to one place clw in the square (1c to W side, 2c to M side) | 1c set to 2c; repeat figure (to 2x,1x) | 2c+1c cross RH) (2,1,3)

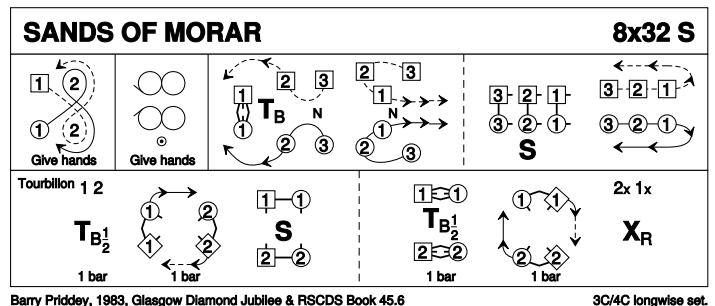

4 A CAPITAL JIG J32 · 3/4L

Tine E MacKay: Magazine Dances 2005-2009 · Crib: E-cribs · Diagram: Keith Rose's Diagrams

- 1- 1c+2c Set&Rotate, finish 1c facing 2c (2,1,3)
- 9- Rsh Reels3 on the sides
- 17- 1c set | turn ¾ RH; 2c+1W & 1M+3c LHA (to 2,1x,3)
- 25- 1c set | turn ¾ RH; 2c+1M & 1W+3c LHA (2,1,3)

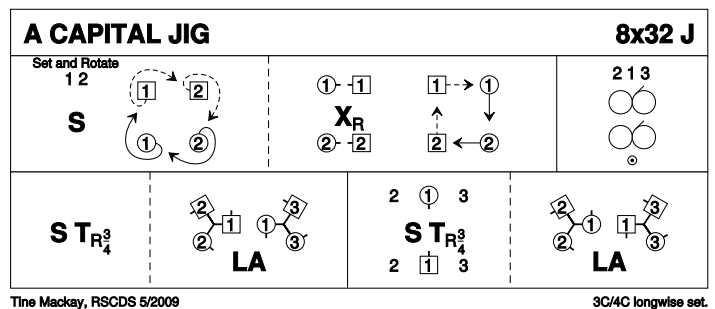

5 THE SALTIRE SOCIETY REEL R32 · 3/4L

Roy Goldring: *The Leaflet Dances with Music* · Crib: *E-cribs* · Diagram: *Keith Rose's Diagrams*

- 1- 1c cross to 2plx (no hands) (2c up) | 1c turn 3c easy hand, to meet between 3c ; 1c dance up NHJ opp. side | 1c turn 2c easy hand, 1c finish in 2plx facing down
- 9- 1c cross down into 2c+1c+3c mirror Reels3 on own sides, 1c finish in middle LHJ each facing own 1cnr
- 17- 1c set to 1cnrs, turning inwards to join RH | set to 3cnr, as these cnrs set advancing and join ; 1c+1cnrs RHA, finish 1cnrs in own places and 1c facing 2cnrs RHJ
- 25- Repeat 17-24 with 2cnrs, interchanging "L" and "R" (to 2,1,3)

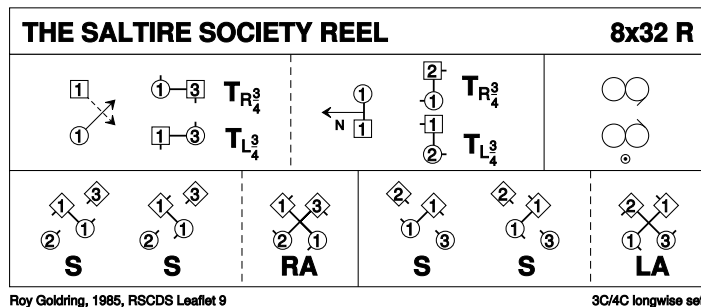

6 THANK YOU GEORGE S32 · 4/4L

Jean-Marc Dorenlot: *The Paris Book of Scottish Country Dances, volume 3* · Crib: *E-cribs* · Diagram: *Keith Rose's Diagrams*

- 1- Parallel Reels4 on sides (1,2,3,4)
- 9- 1c & 4c long cast inwards, joining hands briefly (2c & 3c step out) ; 1c+4c RHA. On [16] 1c & 4c pivot RSh to face nearest cnrs
- 17- 1c+4c Dbl SetH&G. 4c & 1c having changed places diagonally face nearest cnrs
- 25- 4c+2c & 1c+3c turn ¾ EH, 4c & 1c starting out (to 2,4x,1x,3) ; 4c & 1c pass P RSh, face P and cast away to exchanged places (2,4,1,3)

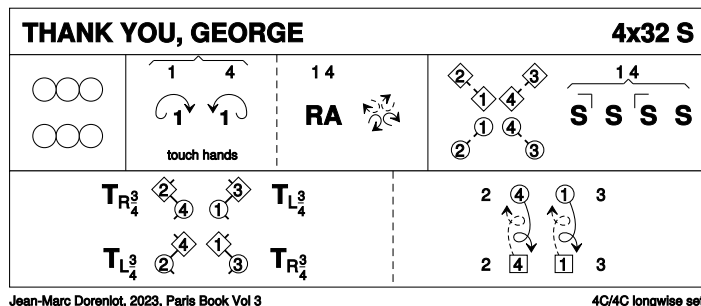

7 MACDONALD OF KEPPOCH M128 · 4S

Chris Ronald: *RSCDS XLIX 11* · Crib: *E-cribs* · Diagram: *Keith Rose's Diagrams*

- 1- 1c+3c ¾ R&L to BtoB facing sides | all set
- 9- Parallel Reels4 across, 1c+3c only do half the last Lsh pass, to end in a line up and down the set
- 17- 1c+3c Lsh Reel4, 1W+3W pass Rsh in middle to start, to finish in original places
- 25- All set to P | all turn P RH 1¼ | all in promhold chase cclw ¼ (2,3,4,1)

The first two turns are in Strathspey time, the second two are in Reel time.

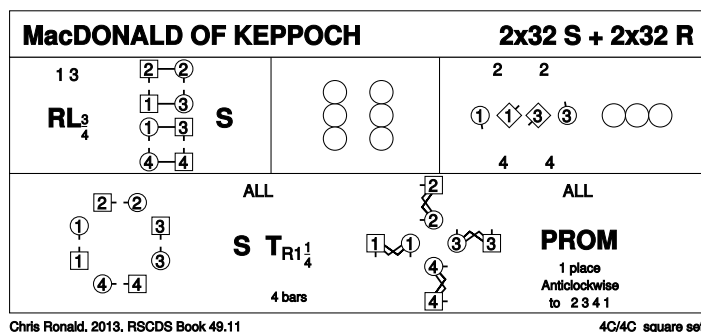

Deuxième partie

8 DANCING DOLPHINS J32 · 3/4L

Barry Skelton: *The Dolphin Book* · Crib: *E-cribs* · Diagram: *Keith Rose's Diagrams*

- 1- 1c cross RH | cast off (2c up) ; turn LH 1¼ to face out and down on W side, 1M behind 1W (see note)
- 9- 2W+1c+3W Rsh lead-change Reel3 on W side (1W leads down, 1M up), at end face out and down on M side
- 17- 2M+1c+3M Lsh lead-change Reel3 on M side, 1c end in promhold facing W side
- 25- 1c pass Rsh round 3W, dance to top and cast to 2pl

Note: during the reels 1M and 1W always cover parallel to the sidelines.

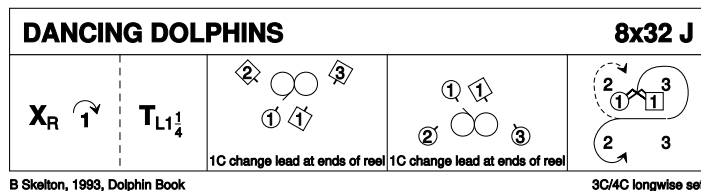

9 THE CASTLE OF MEY R32 · 3/4L

John Walton: QE Diamond Jubilee Dances · Crib: E-cribs · Diagram: Keith Rose's Diagrams

- 1- Inveran Reels 3 on the sides, 1c crossing down to start (1,2,3)
- 9- 1c+2c Dbl Fig 8, 1c cross down to start
- 17- 1c lead down the middle and up, finishing for
- 25- 1c+2c Poussette

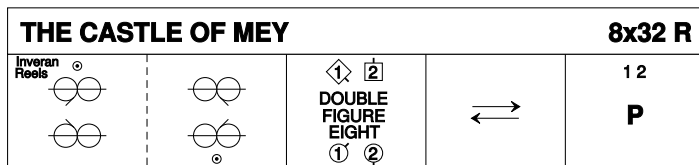

John Walton, 2012, RSCDS QE Diamond Jubilee

3C/4C longwise set.

10 BRUNETTE D'ECOSSE S32 · 3/4L

Ann Dix: Reel Friends Book 2 · Crib: E-cribs · Diagram: Keith Rose's Diagrams

- 1- 1c+2c S&Link ; 2c+1c+3c set, advancing on 2nd step | Turn P BH into
- 9- 3C Allemande, 1c finish facing 1c (3,1,2)
- 17- 1c set to and turn 1c BH ; repeat with 2c, 1c finish Lsh touching in middle facing own side
- 25- All (1c merging in) chase ½ clw ; all C turn BH 1½ (to 2,1,3)

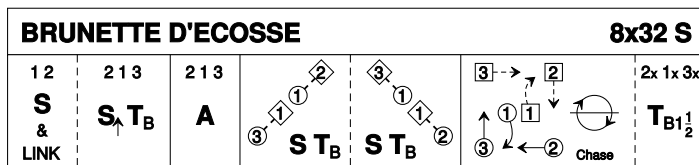

Ann Dix, 1993, Reel Friends 2

3C/4C longwise set.

11 THE ELPHINSTONE JIG J32 · 3/4L

John Drewry: Deeside Book Part 2 · Crib: E-cribs · Diagram: Keith Rose's Diagrams

- 1- 1W+3M change pl RH, cast clw to P's right, NHJ ; 1c+3c dance across and cast clw to 3pl facing 1pl in the middle **while(4)** 2c set adv, pull back Rsh and skip-change to places.
- 9- 3c+1c+2c Circle 6 and back, finish 3c facing 1c in the middle (3,2,1)
- 17- 3c+1c set | 3c+1c RHA | 3c cast to 3pl **while(2)** 1c dance to 1pl and face out.(1,2,3)
- 25- 1c+2c ¾ Dbl Fig 8 (2c cross up) | 1c cross RH to 2pl. (2,1,3)

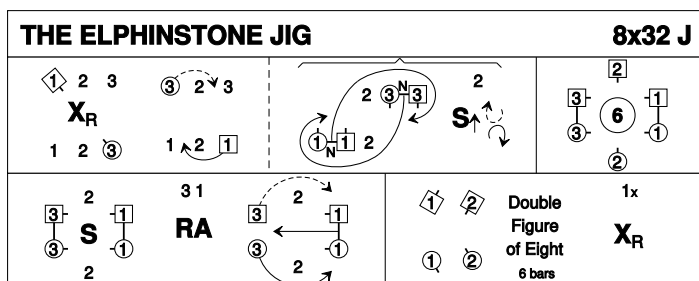

John Drewry, 1981, Quincentenary SCDs

3C/4C longwise set.

12 ANNA'S WEDDING CAKE S32 · 3/3L

Brenda Janssen: Celebrate Fifty Years of Dancing with the Boston Branch · Crib: E-cribs · Diagram: Keith Rose's Diagrams

- 1- 1c turn BH, cast off one (2c up) ; ½ Fig 8 R (M down, W up) (2,1x,3)
- 9- Teapots R (2c+1M & 1W+3c RHA) (2,1x,3) ; 1c ½ Fig 8 L (M down, W up) (2,1,3)
- 17- 1c+3c Set&Rotate (set to P | cast 1 place clw ; change place RH with P | chase 1 place clw)
- 25- 2c+3c+1c circle 6 and back

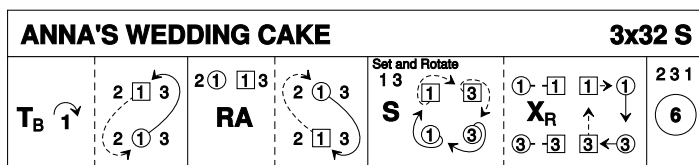

Brenda Janssen, 1996, Boston 50

3C/3C longwise set.

13 SCOTT MEIKLE R32 · 4/4L

Alice McLean: RSCDS XLVI 3 · Crib: E-cribs · Diagram: Keith Rose's Diagrams

- 1- 1c cross RH | cast (2c up) ; ½ Fig 8 up (2,1,3,4)
- 9- 1c+3c RHA, LHA (2,1,3,4)
- 17- Lsh opposing Reels 3 across: (1W+3W behind dancing as one) with 2c and (3M+1M behind) with 4c (to 2,3,1,4)
- 25- 1c+4c ½ R&L ; turn RH 1½ (2,3,4,1)

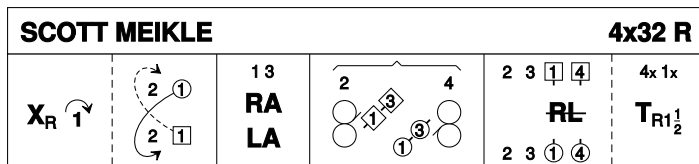

Alice McLean, Laurieston Collection 1, RSCDS Book 46.3

4C/4C longwise set.

14 DA RAIN DANCIN' R32 · 3/4L

Ron Wallace: *Thirty Popular Dances, Volume Two · Crib: E-cribs · Diagram: Keith Rose's Diagrams*

- 1- 1c dance down 2 places and cast up to 2pl (2c up) ;
2c+1c+3c set and cross RH (2x,1x,3x)
- 9- 1c dance up and cast off one ; 2c+1c+3c set | 2c+3c
cross LH **while**{2} 1c turn LH to face 1cnr:
- 17- 1c set R to 1cnr {1} and L to P {1} | turn ¾ RH ; set R to
2cnr and L up/down to P | turn ¾ RH to 2pl
- 25- 2c+1c+3c circle6 and back. (2,1,3)

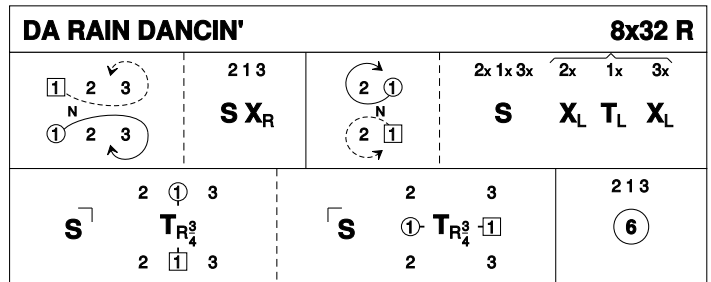

Ron Wallace, 1991, Whiteadder Collection, RSCDS Thirty Popular Dances Vol 2

3C/4C longwise set.